

# Montageanleitung

Raffstore mit Elektroantrieb und Führungsschienen

EL 60N / EL 80N / EL 60NF / EL 80NF



**Die Montage ist ausschließlich durch qualifiziertes Fachpersonal auszuführen!**

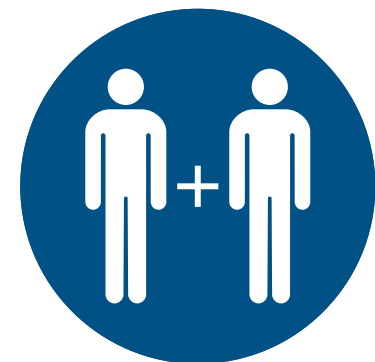



# Montage vorbereiten



**Bei der Montage ist darauf zu achten, dass die Auswahl des Befestigungsmaterials in Abstimmung mit dem jeweiligen Montageuntergrund erfolgt.**

# Benötigte Werkzeuge

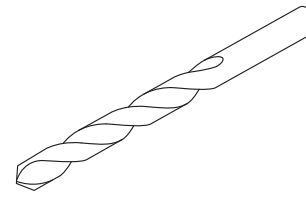
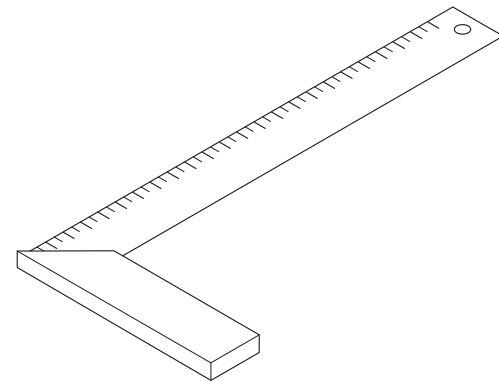
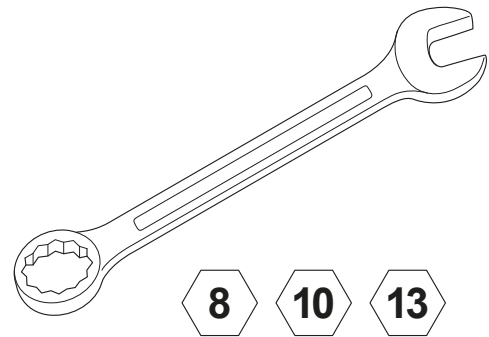

Ø = 13 mm

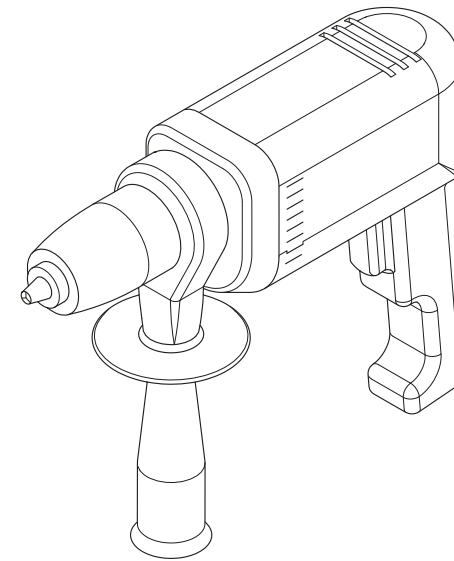

\*\*\*Einstellkabel nur bei elektronischem Motor und bei Änderung der Endlage nötig.

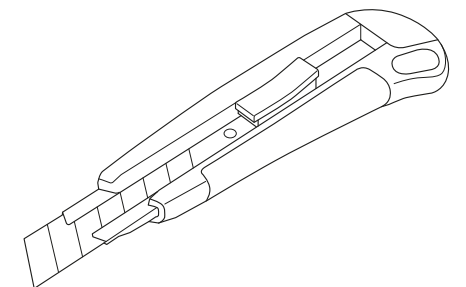
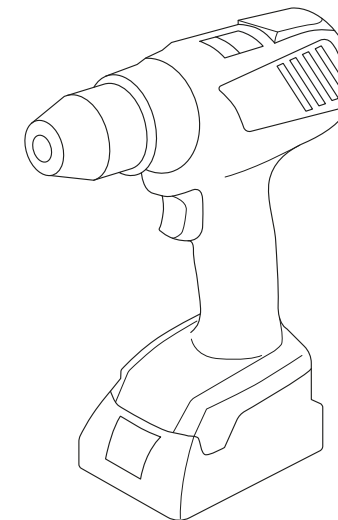
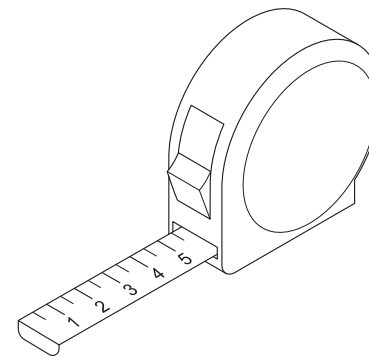
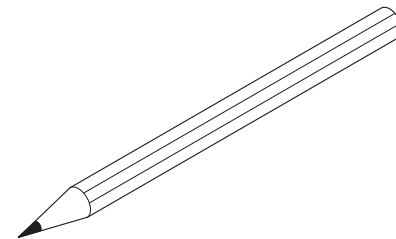
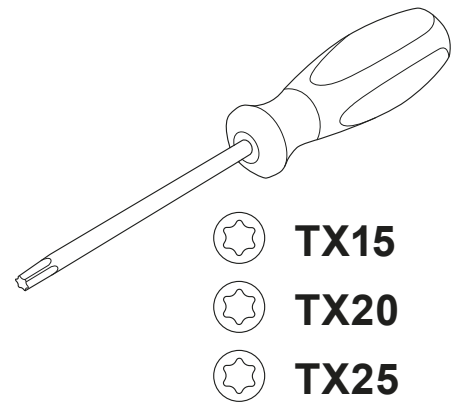
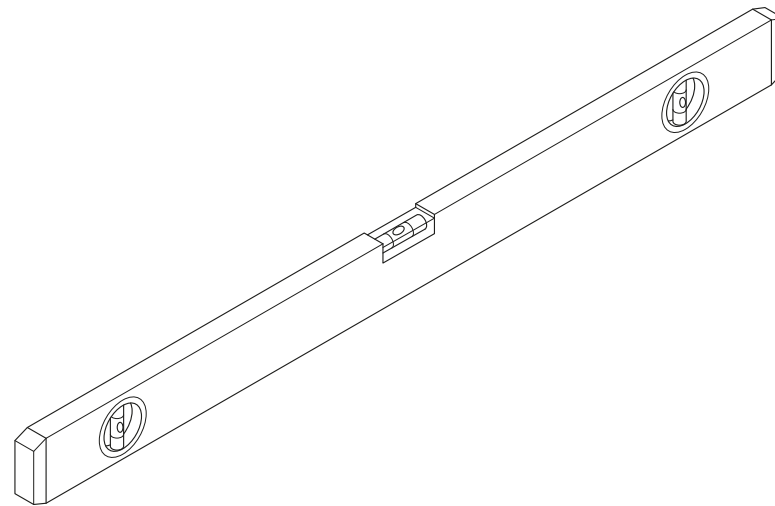
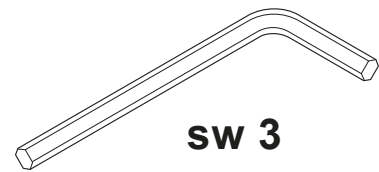
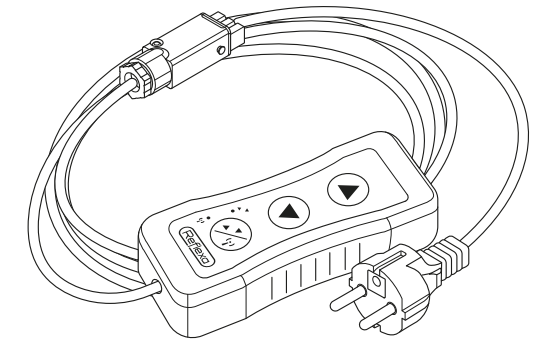

# Lieferumfang

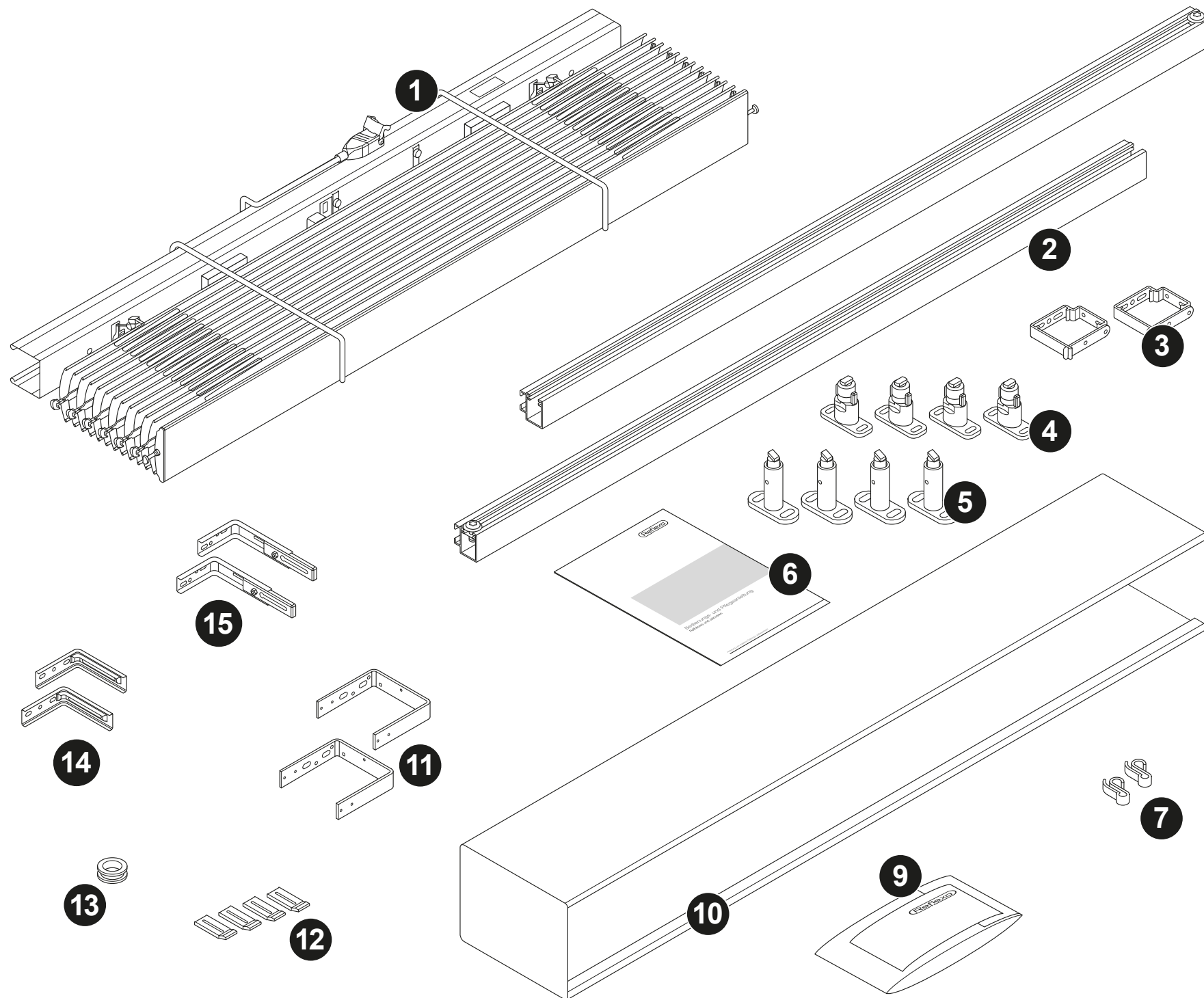

Nr.	Bezeichnung	
1	Raffstorepaket	
2	Führungsschienen	
3	Oberschiententräger	
4	Abstandshalter Typ X70	
5	Abstandshalter Typ A/B/C	optional
6	Bedienungs- und Pflegeanleitung	
7	Kabelklemme	
8	Hirschmann-Kupplung STAK3	
9	Montageset(s)	optional
10	Blende (Form U/W)	
11	Versteifungsbügel	optional
12	Verlängerungsstück	optional
13	Schutztülle	
14	Trägerkonsole KT	optional
15	Trägerkonsole KT mit Schlitten	optional

43000413

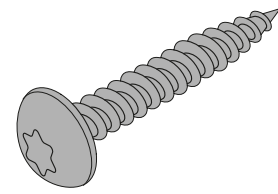

**10x**

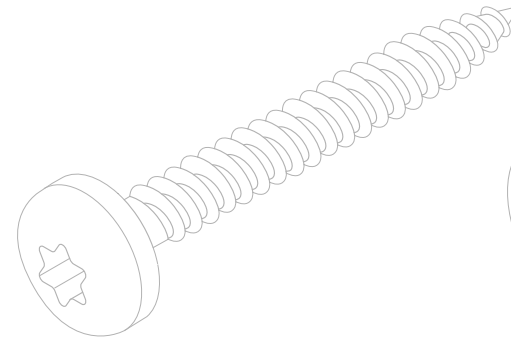

**10x**

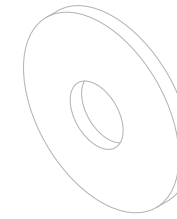

**10x**

Montageschrauben in Richtung Baukörper  
bei Onlinebestellungen nicht im  
Lieferumfang enthalten.

Systemschrauben von Raffstore und  
Blende im Lieferumfang enthalten.

43000415

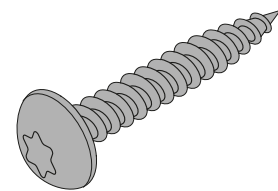

**20x**

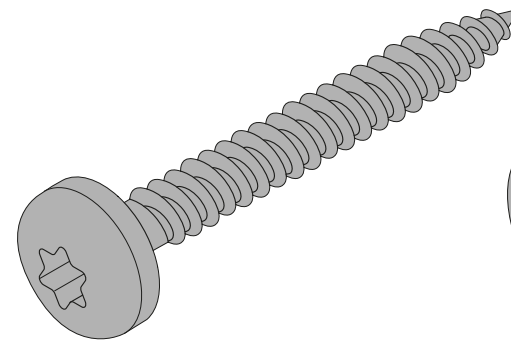

**20x**

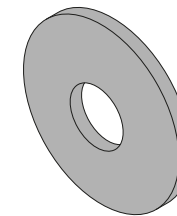

**20x**

43000415

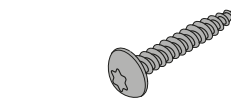

Typ A, Typ C

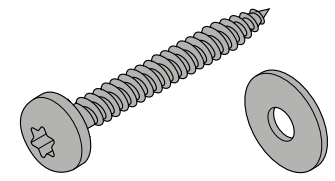

Typ B

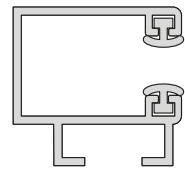

Typ T

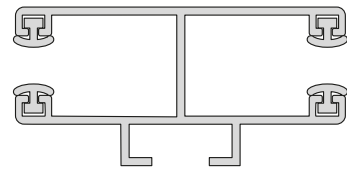

Typ D

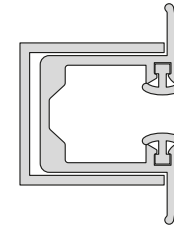

Typ P

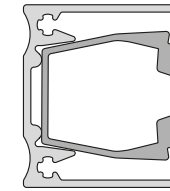

Typ E30

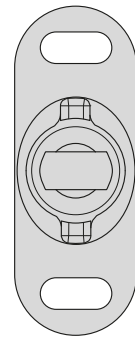

Typ X70

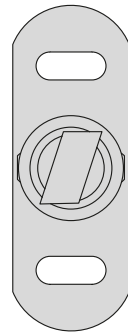

Typ A

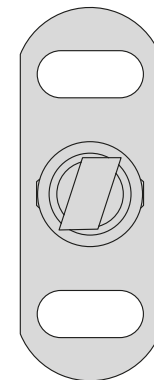

Typ B

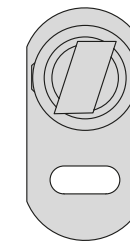

Typ C

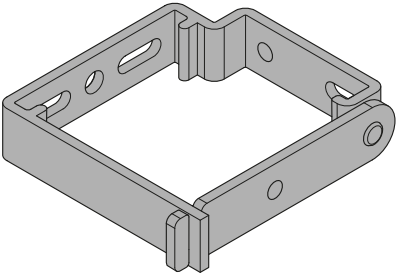

# Anzahl der Oberschiententräger im Verhältnis zur Anlagenbreite

	$\leq 1.500 \text{ mm}$	$\leq 3.000 \text{ mm}$	$\leq 4.500 \text{ mm}$	$\leq 6.000 \text{ mm}$
	2 x	3 x	4 x	5 x

# Maßbezüge der Trägerelemente Anlagen Typ EL 60N / EL 80N



Bei mehr als zwei Trägern diese ausmitteln, jedoch mind. 85 mm neben einer Bandspule.

EL 60N, EL 80N		
Lamellenlänge (in mm)	≤ 740	> 740
Maß B (in mm)	150	100

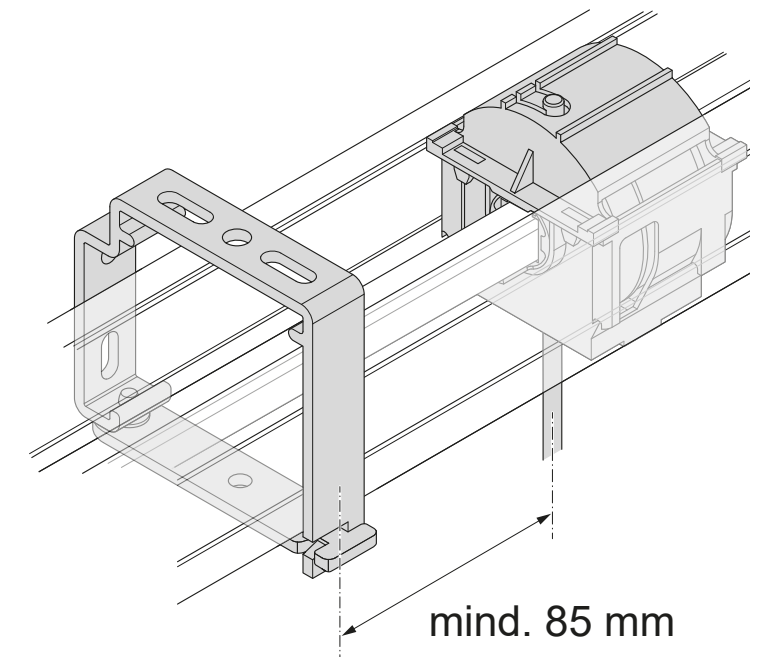
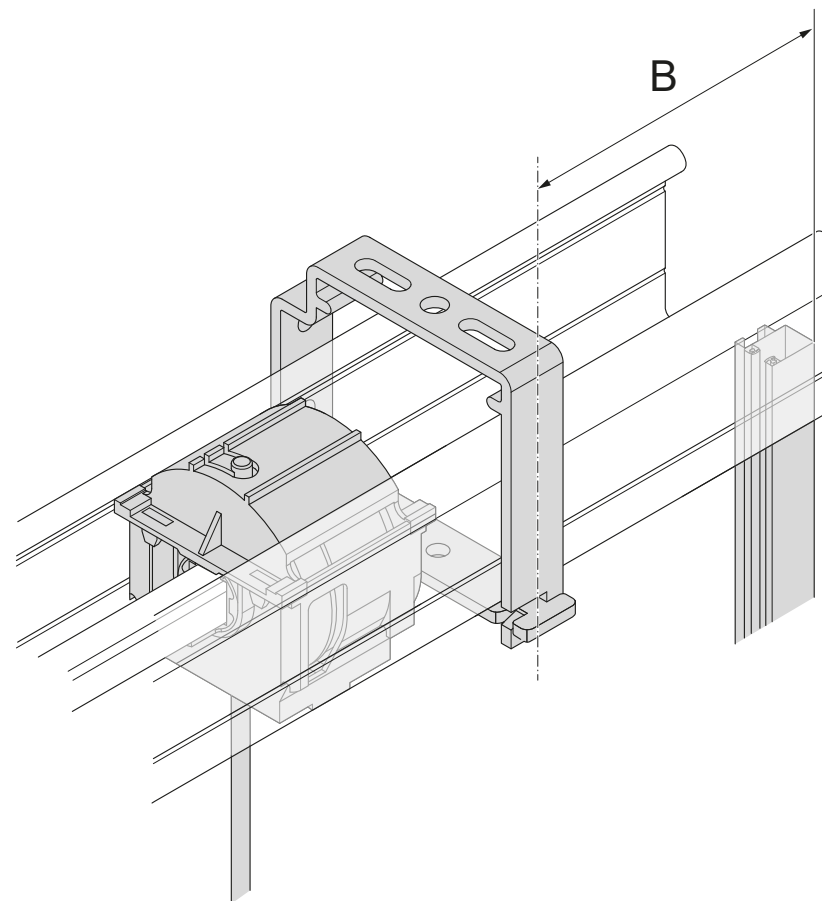
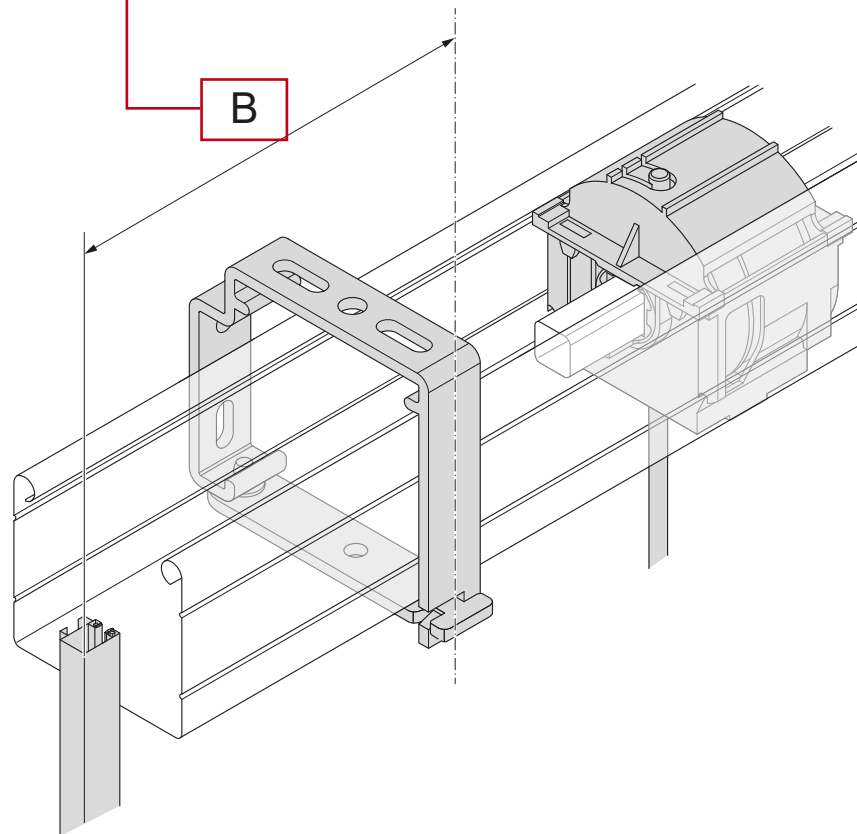

# Maßbezüge der Trägerelemente bei Anlagen Typ EL 60NF/EL 80NF



Bei mehr als zwei Trägern diese ausmitteln, jedoch mind. 85 mm neben einer Bandspule.

EL 60NF, EL 80NF • Anlagenhöhe > 2.750 mm		
Lamellenlänge (in mm)	≤ 650	> 650
Maß B (in mm)	140	100

EL 60NF, EL 80NF • Anlagenhöhe ≤ 2.750 mm		
Lamellenlänge (in mm)	≤ 800	> 800
Maß B (in mm)	140	100

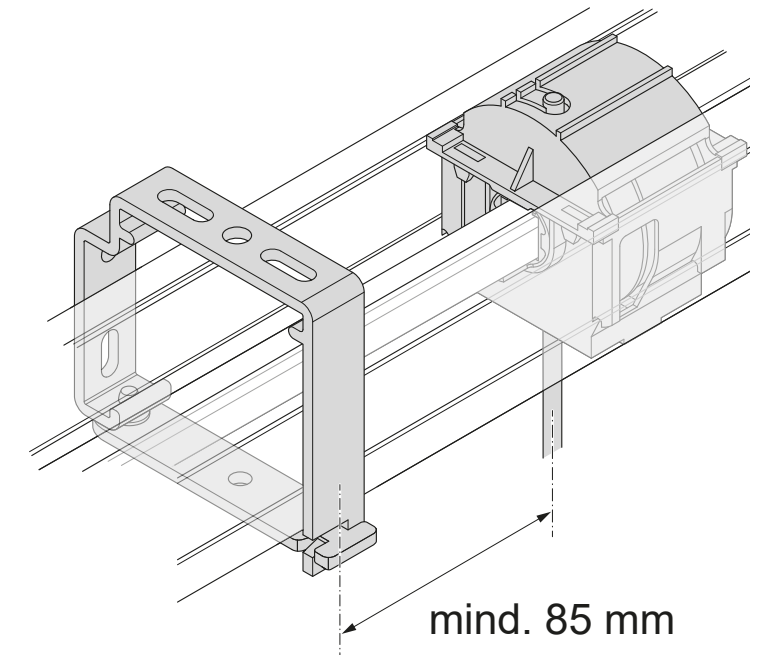
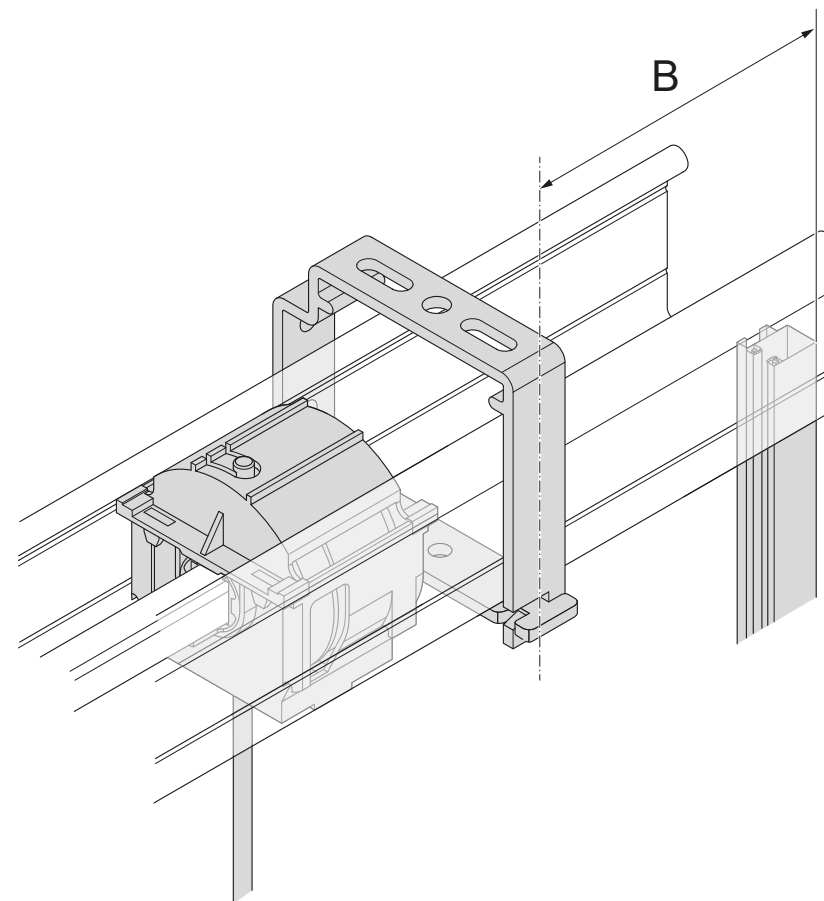
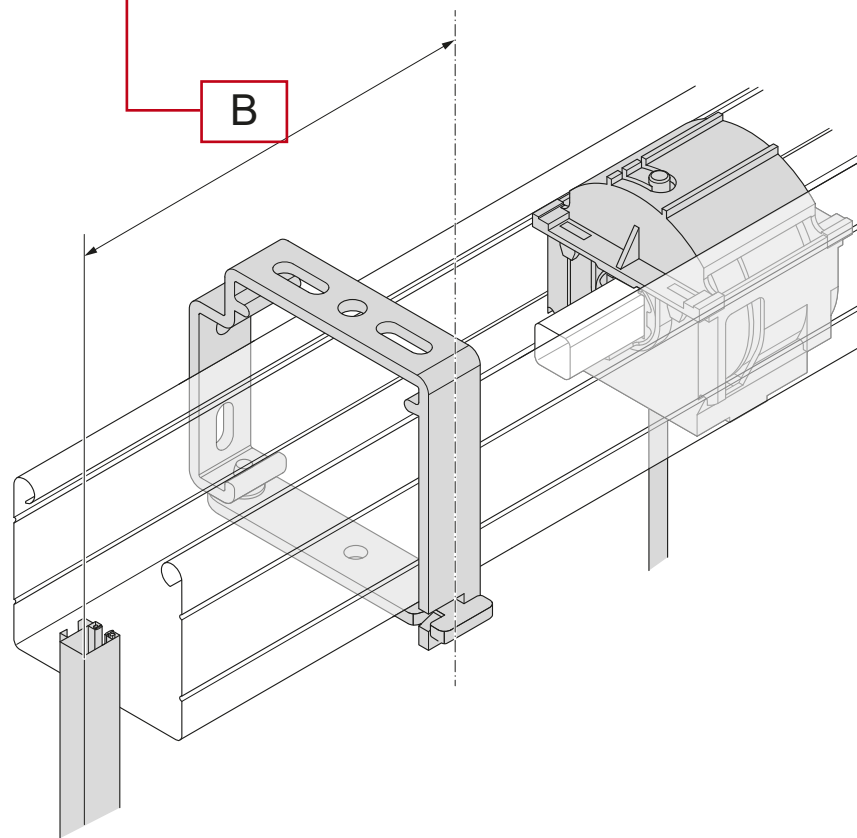

## Maßbezug X-Maß/Abstandshalter Typ X70



Das „X-Maß“ beschreibt den Abstand zwischen Montageuntergrund und der Mitte des Raffstorepaketes.

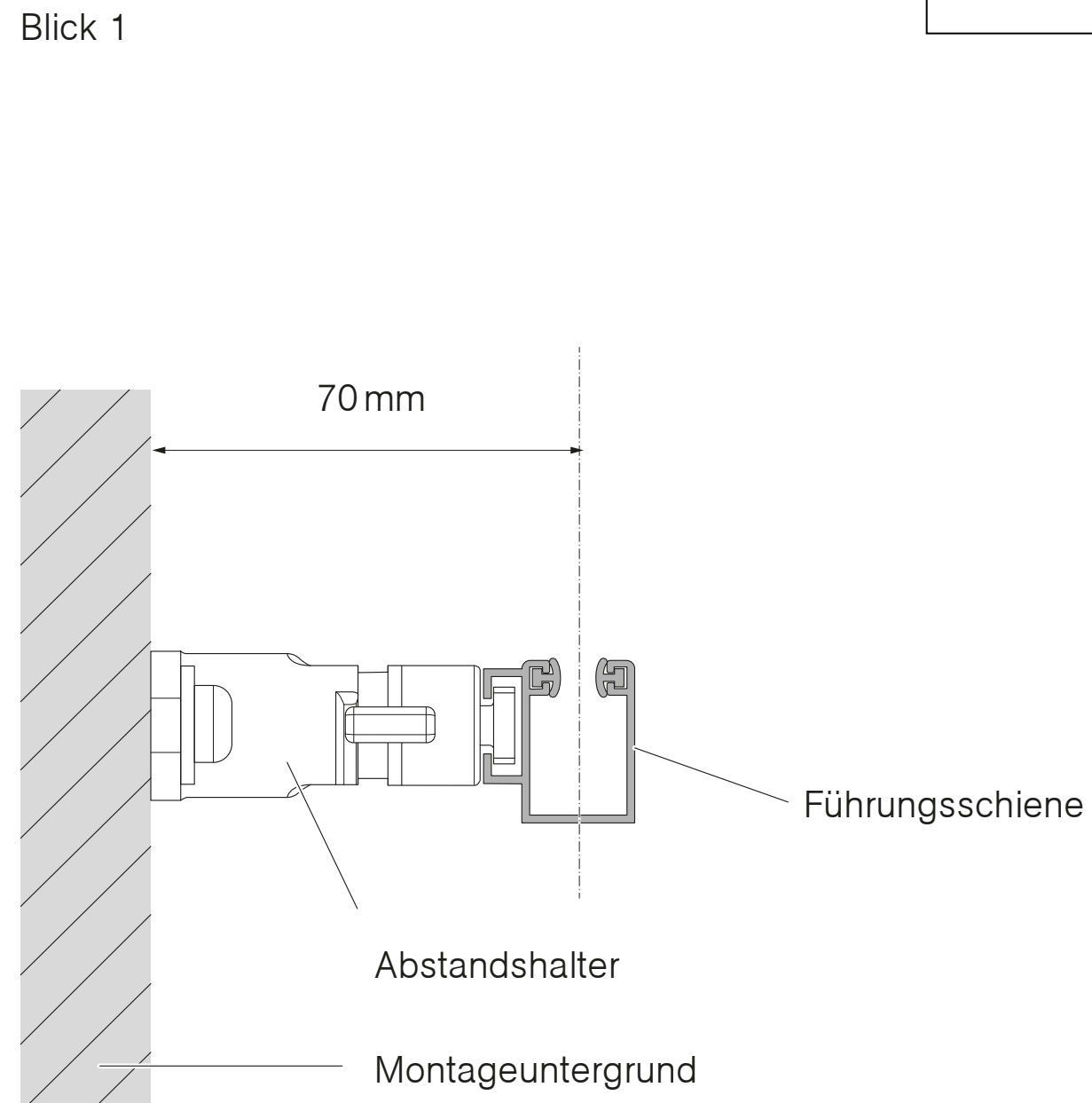
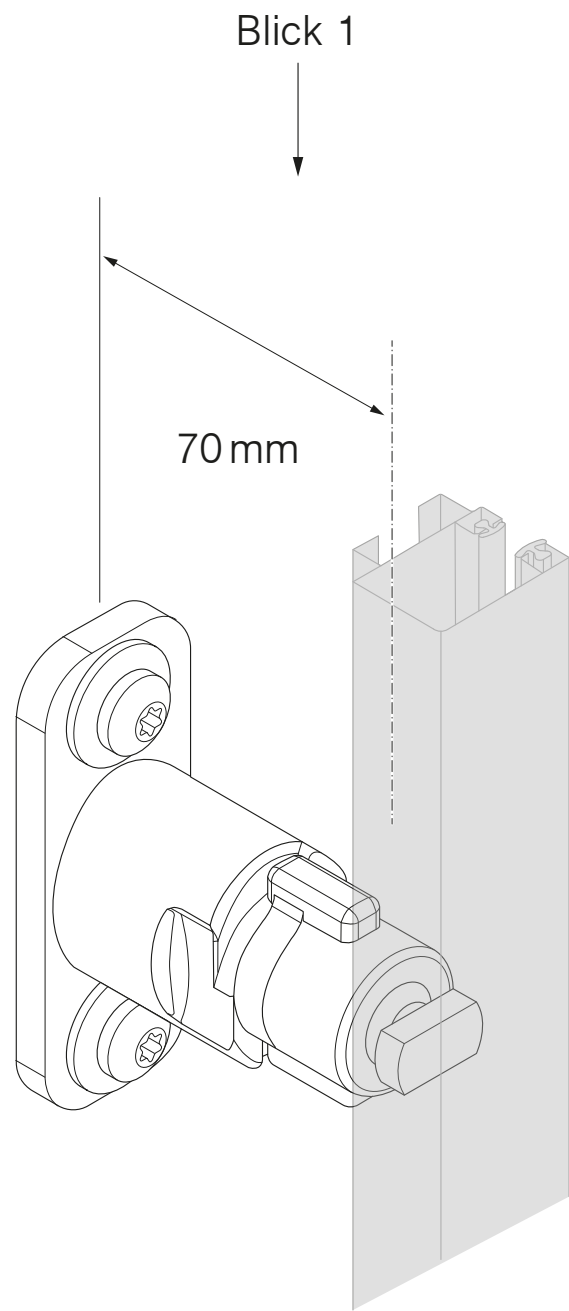

# Maßbezug X-Maß/Abstandshalter Typ A/B/C



Das „X-Maß“ beschreibt den Abstand zwischen Montageuntergrund und der Mitte des Raffstorepaketes.

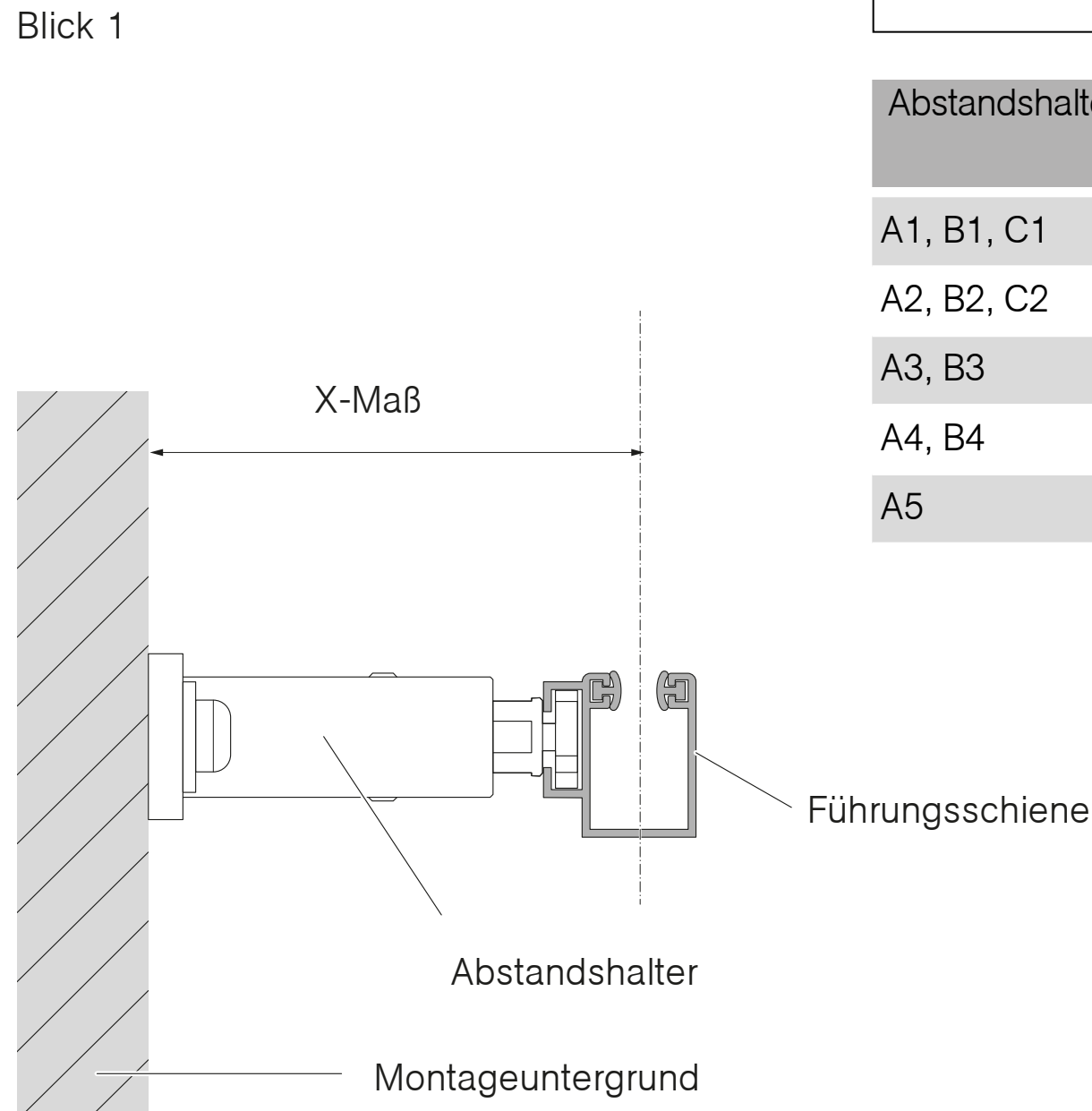
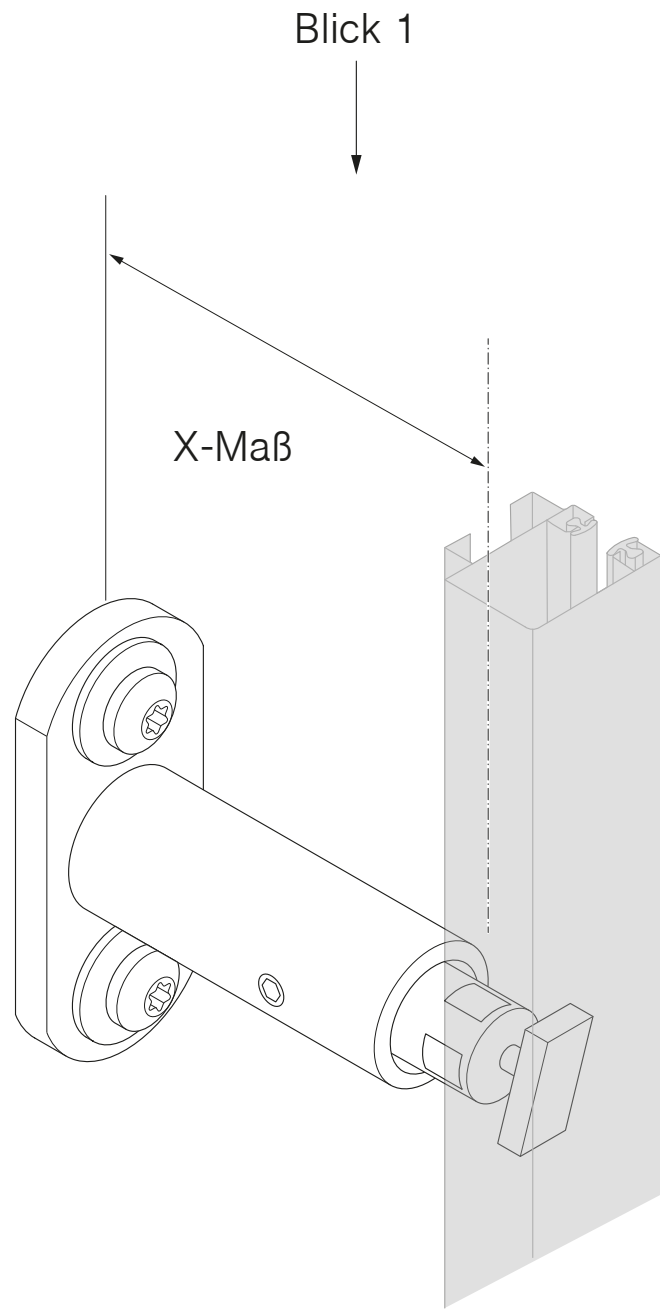

Abstandshalter	X-Maß bei Führungsschienen Typ T und D*
A1, B1, C1	45 – 61 mm
A2, B2, C2	62 – 81 mm
A3, B3	82 – 111 mm
A4, B4	112 – 160 mm
A5	161 – 200 mm

\*siehe Seite 8

# Maßbezug X-Maß/Abstandshalter Typ A/B/C



Das „X-Maß“ beschreibt den Abstand zwischen Montageuntergrund und der Mitte des Raffstorepaketes.

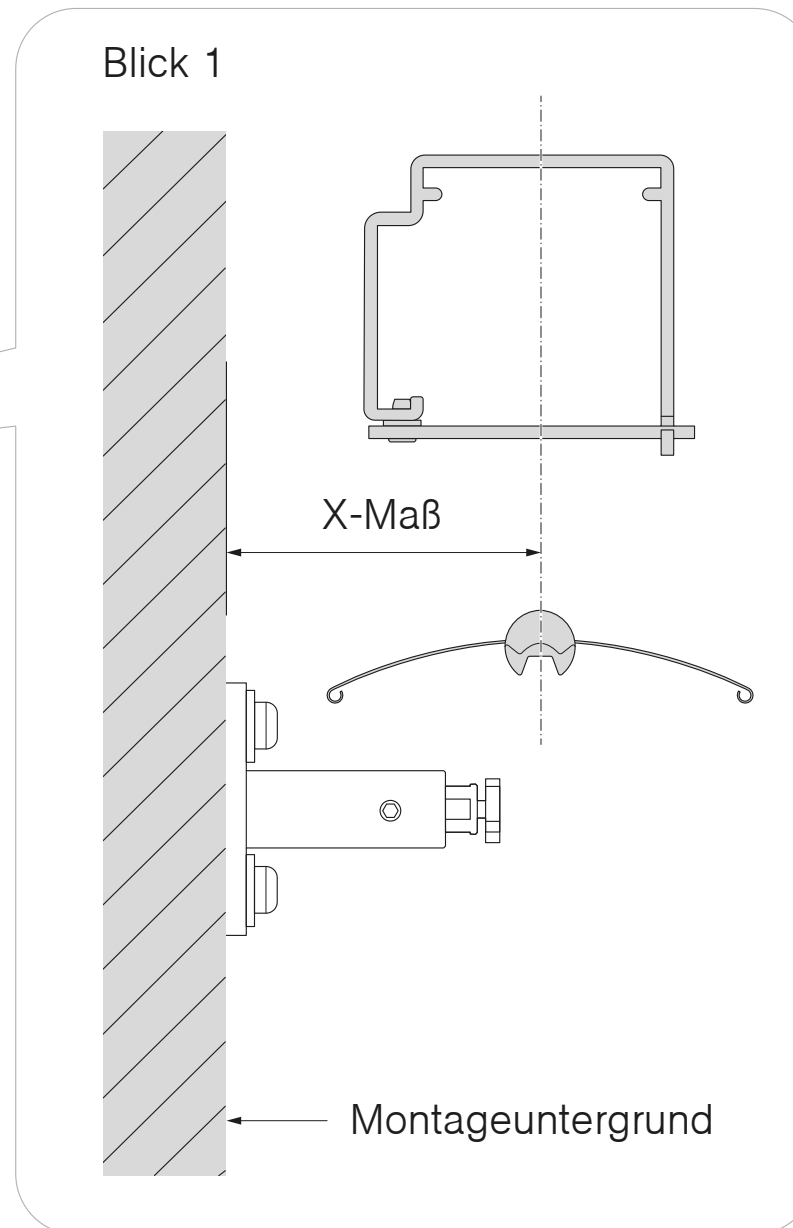
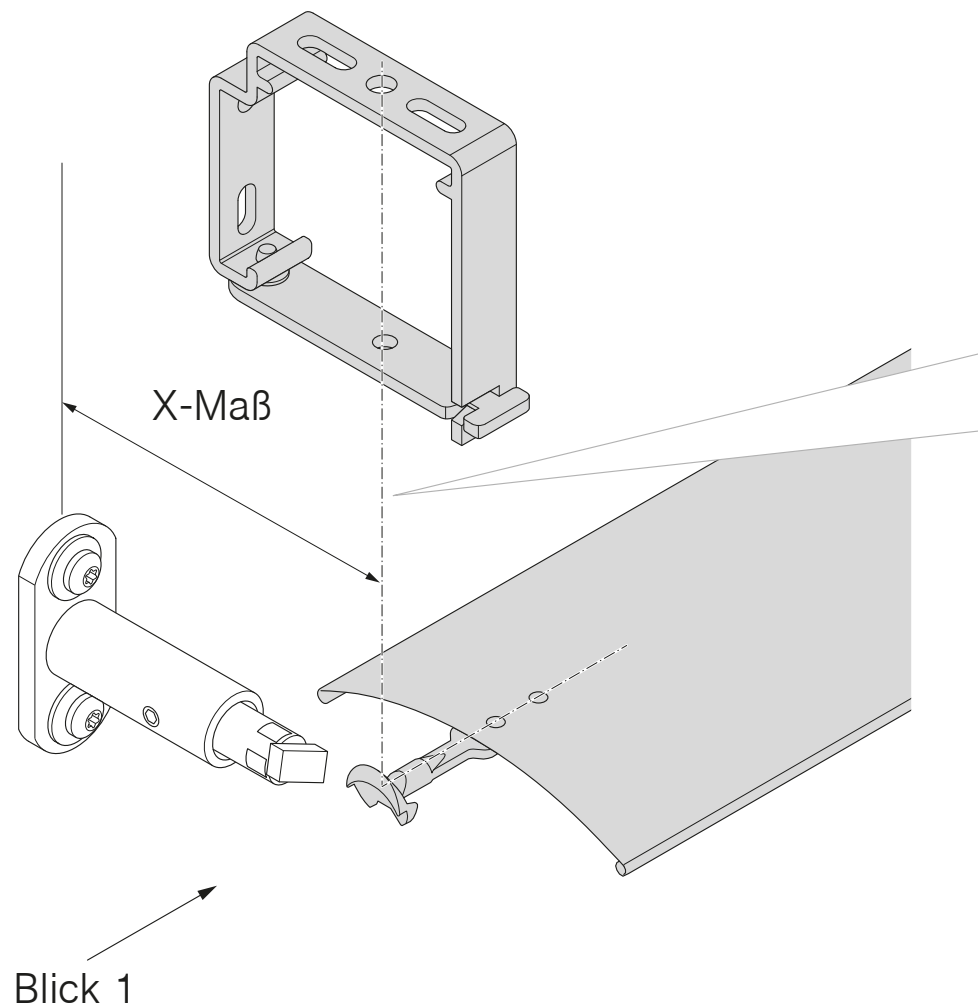

Abstandshalter	X-Maß bei Führungsschienen Typ T und D*
A1, B1, C1	45 – 61 mm
A2, B2, C2	62 – 81 mm
A3, B3	82 – 111 mm
A4, B4	112 – 160 mm
A5	161 – 200 mm

\*siehe Seite 8

# 2

## Oberschienenenträger/Blende anbringen

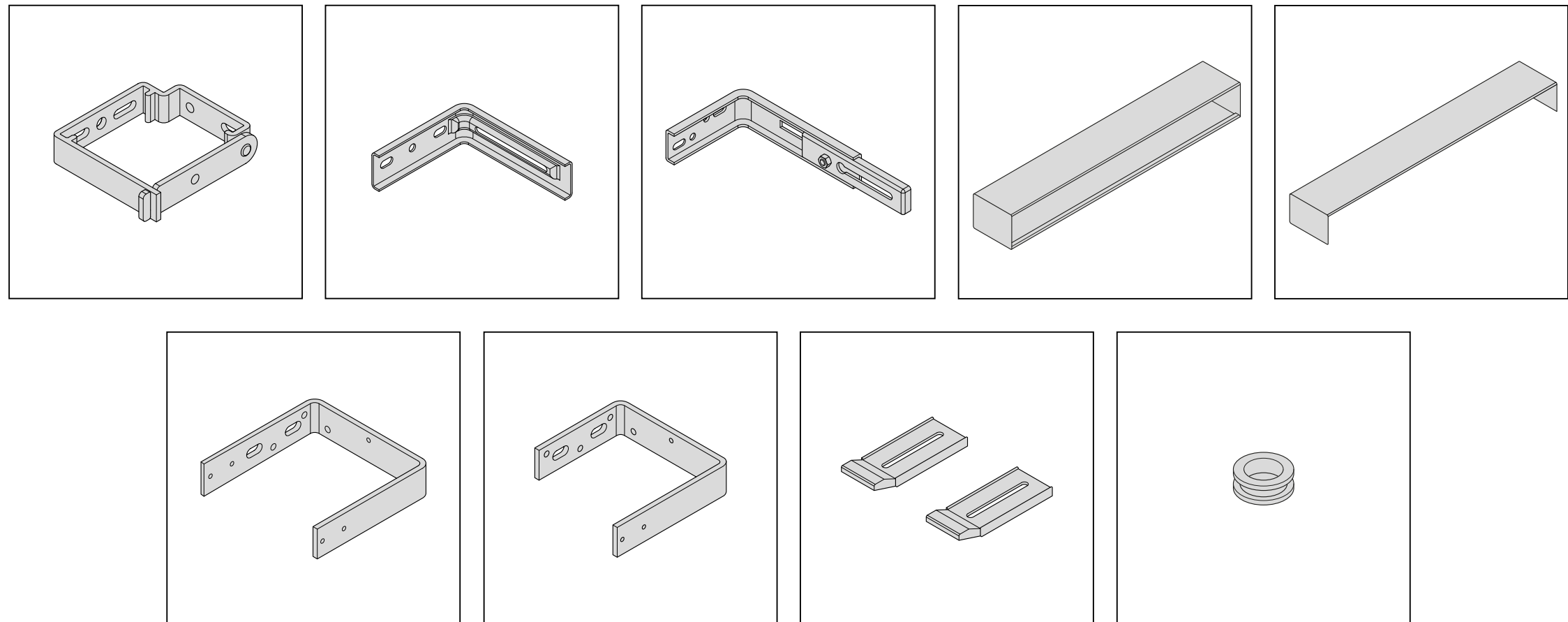

# Raffstorepaket mit Führungsschiene mittig anzeichnen

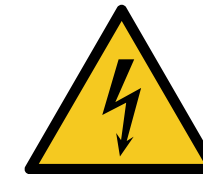

Es ist sicherzustellen, dass während der Montage alle stromführenden Leitungen vom Netz getrennt sind!

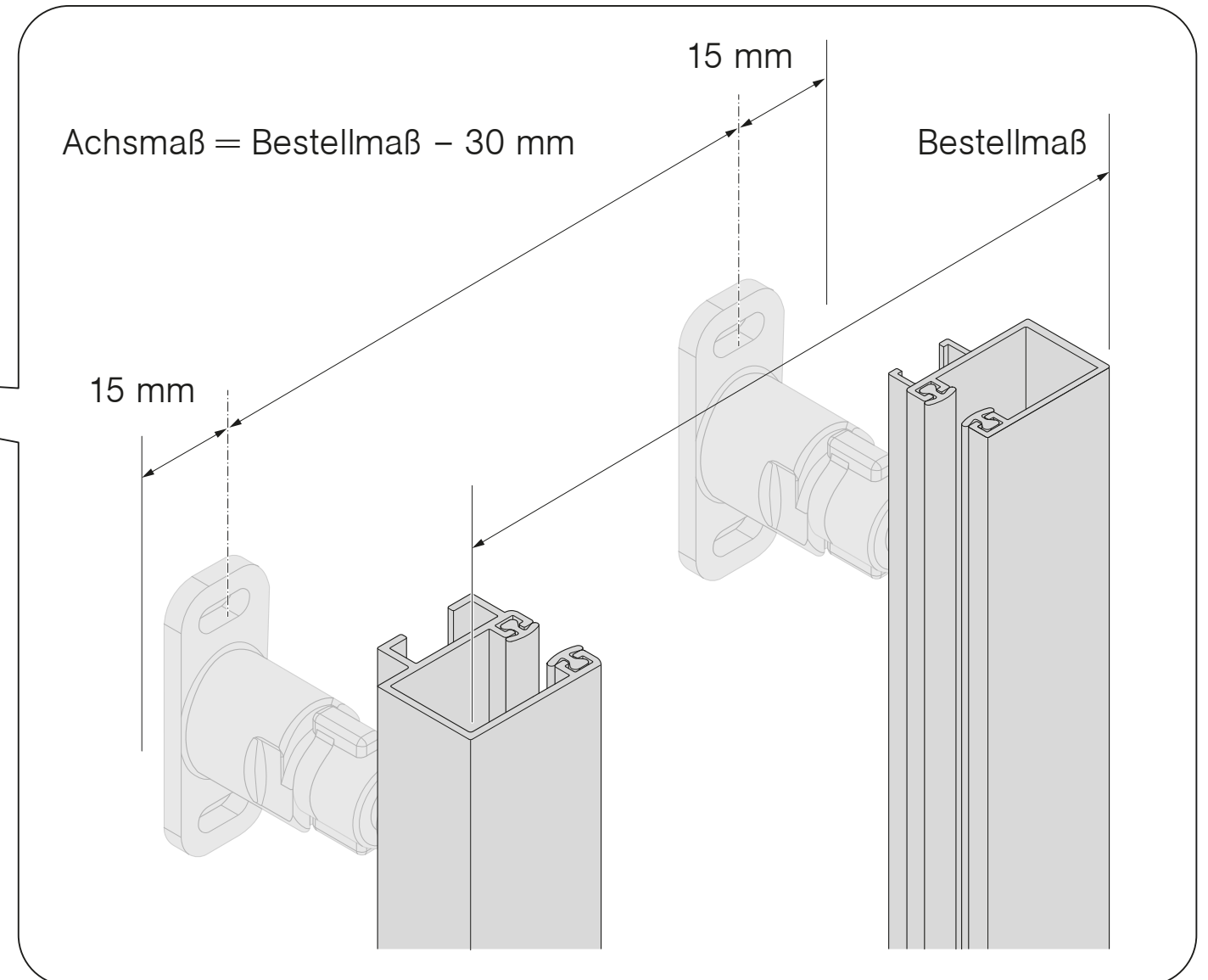
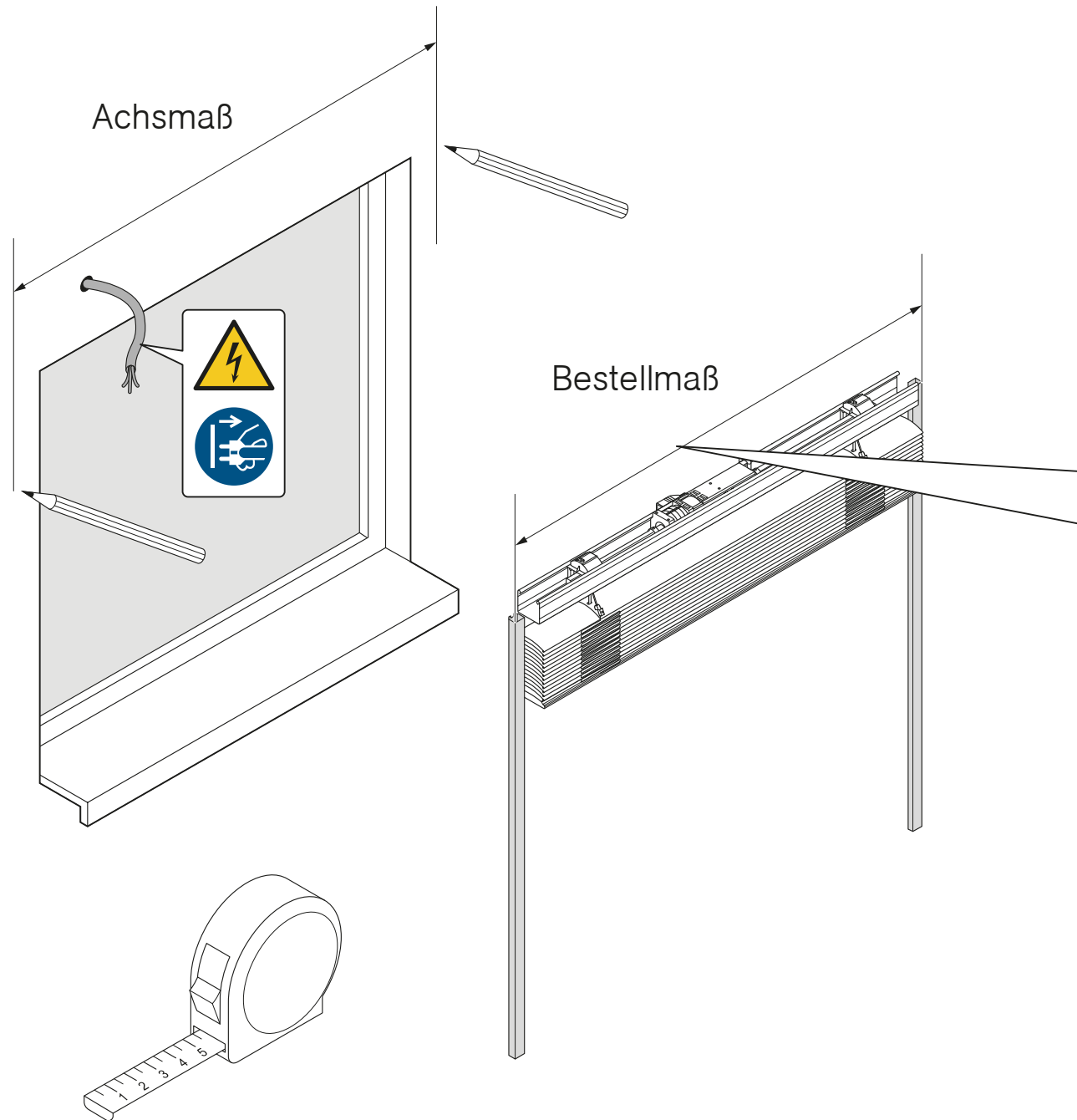



# Generelle Position des Oberschienenenträgers



X-Maß: siehe Seite 12  
B: siehe Seite 10 ff.

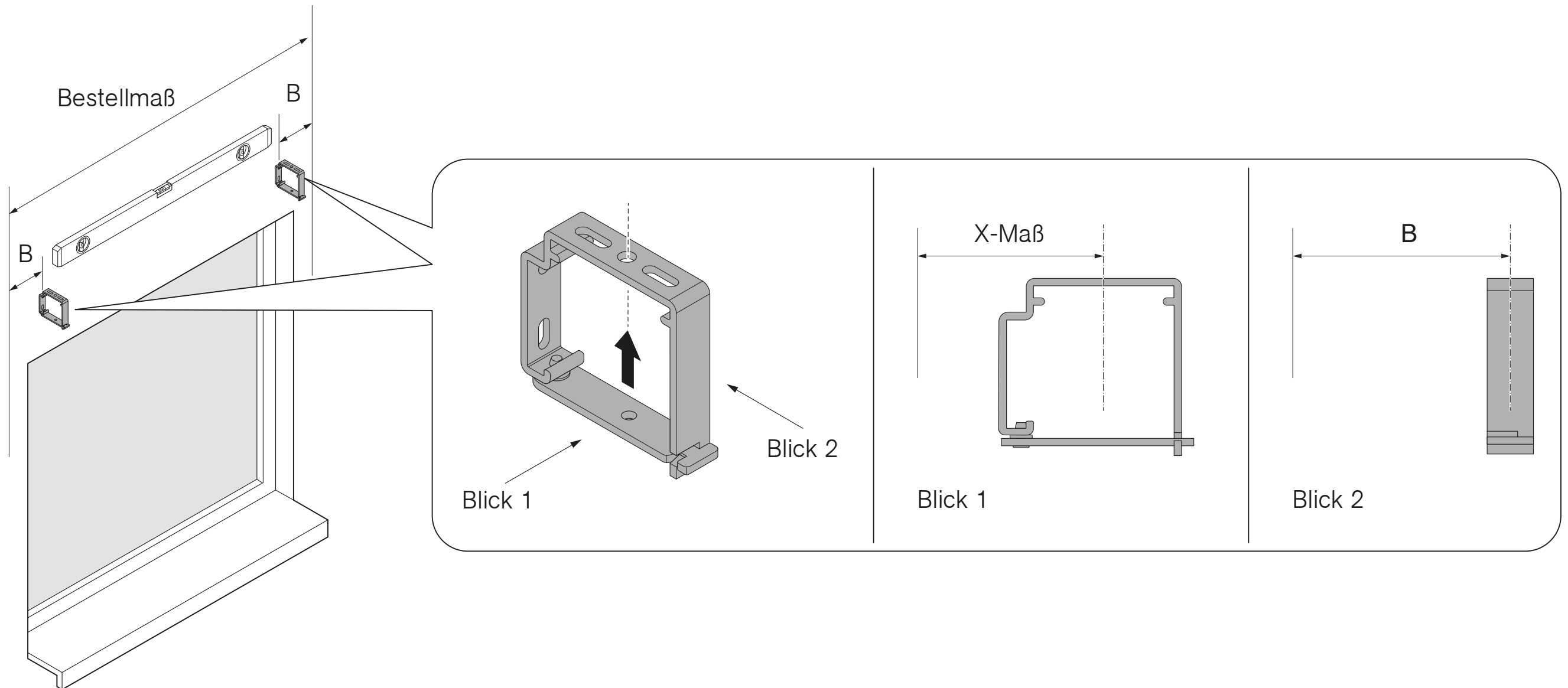

# Generelle Position des Oberschiენტräger

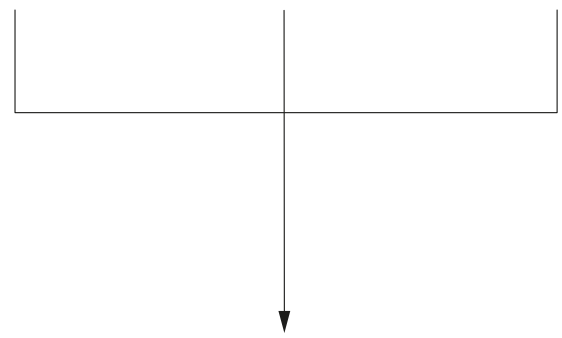
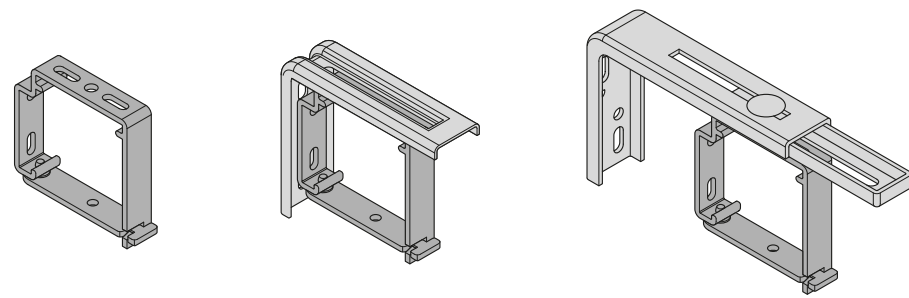
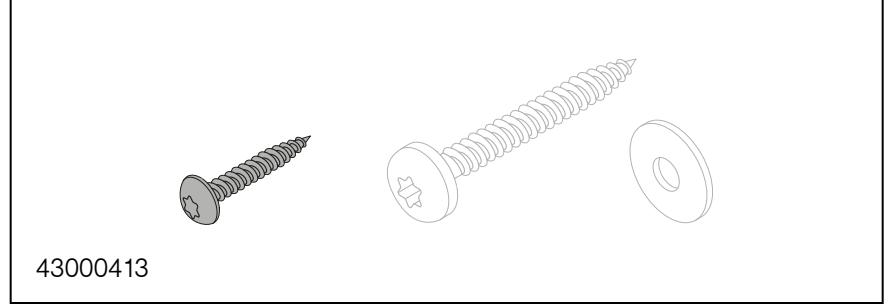

19

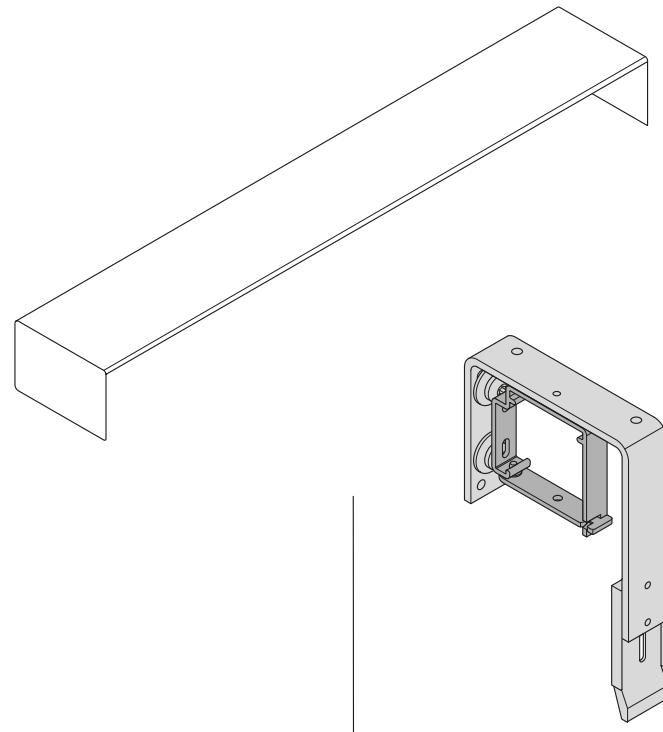

20

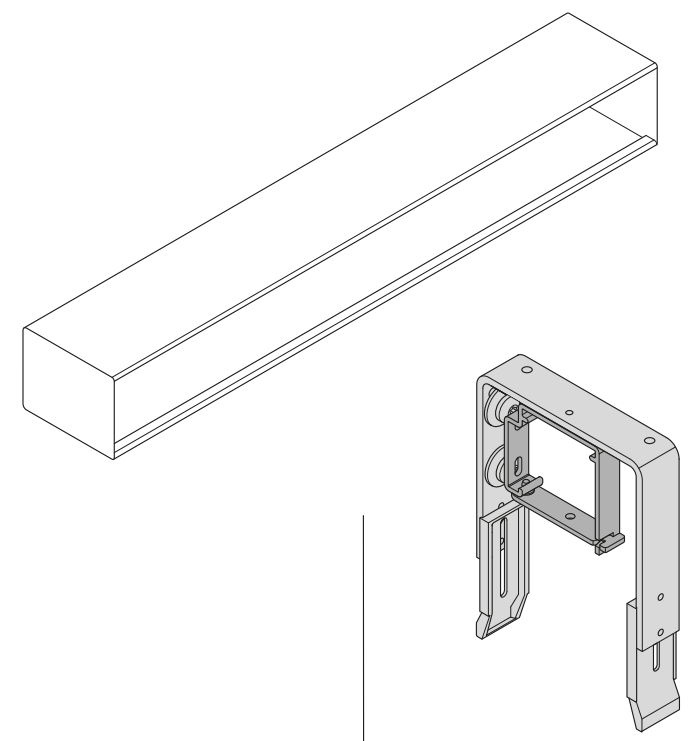

24

# Oberschienenträger montieren

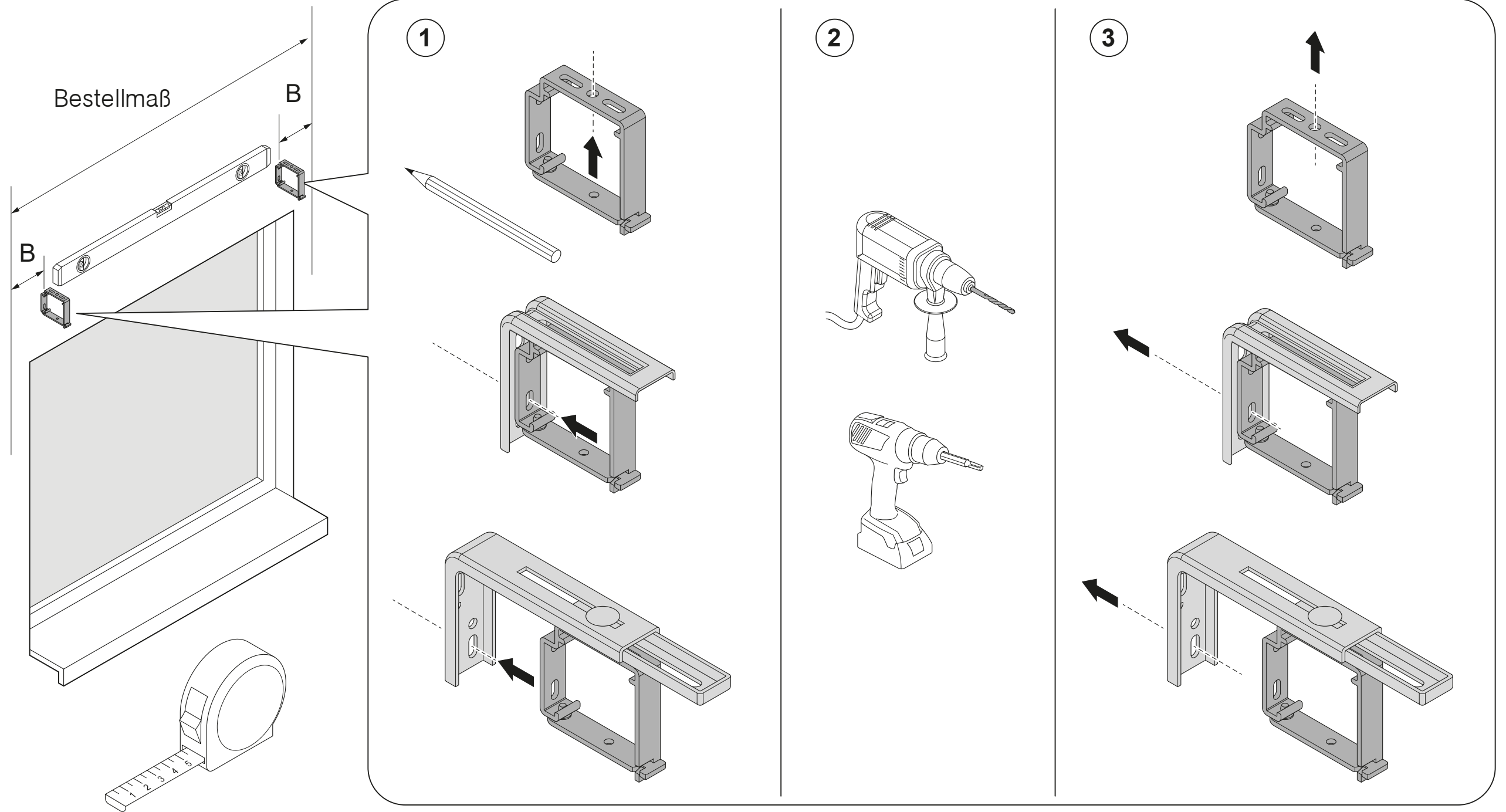

# Versteifungsbügel für Winkelblende montieren

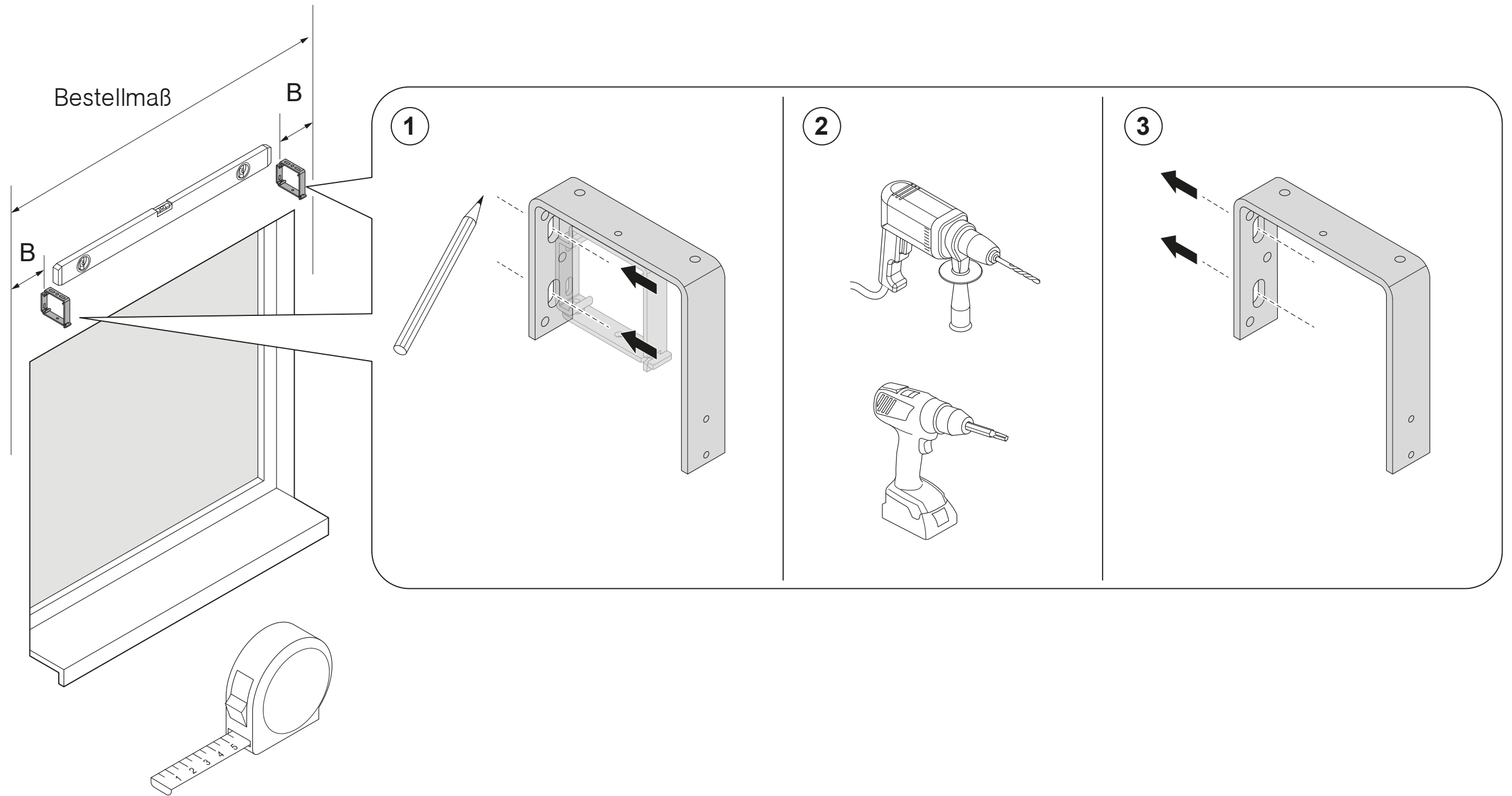

# Winkelblende mittig zum Achsmaß am Versteifungsbügel befestigen



Auf sorgfältige Kabelführung achten.  
Befestigungsmaterial nicht im Lieferumfang enthalten.

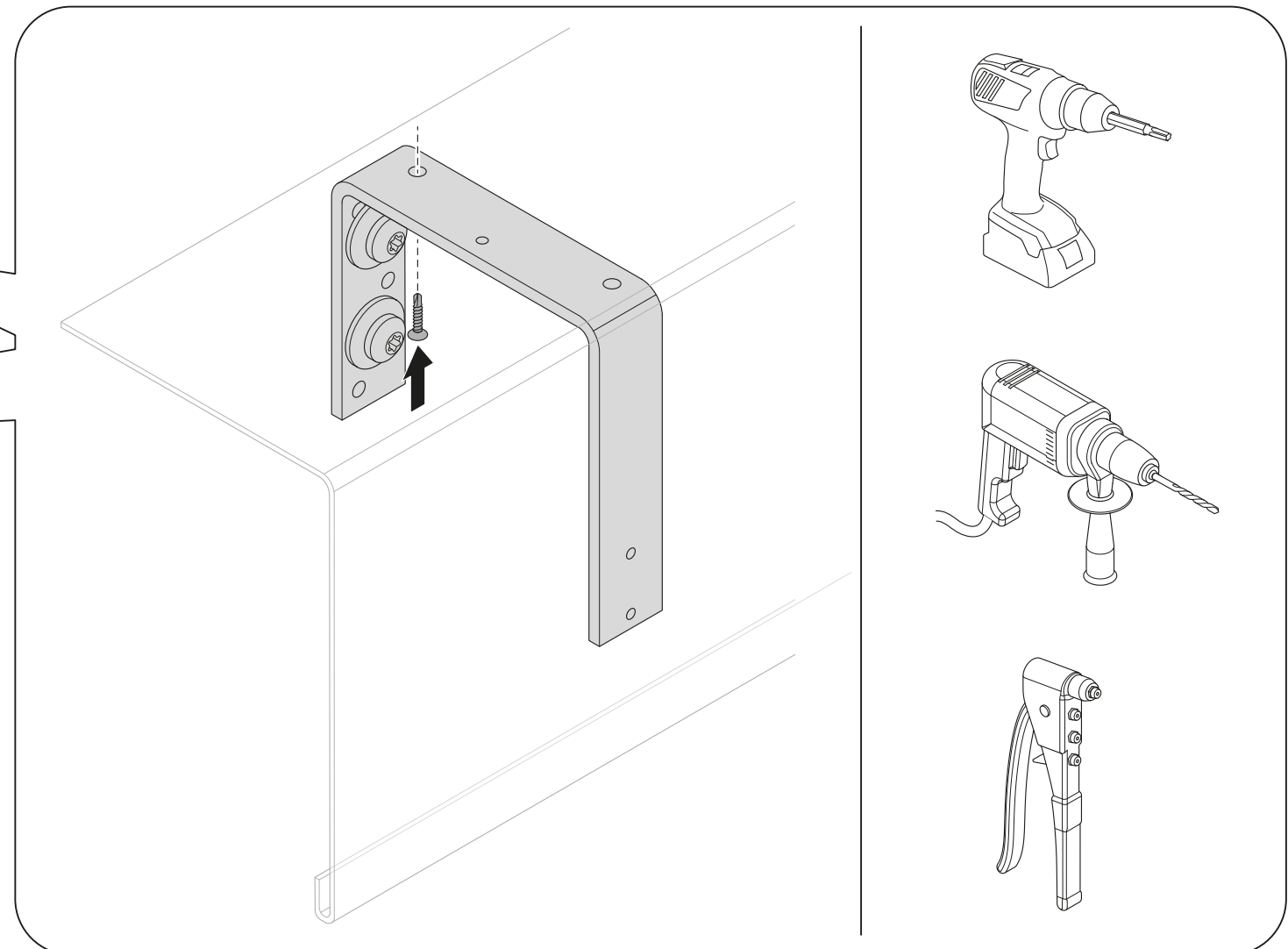
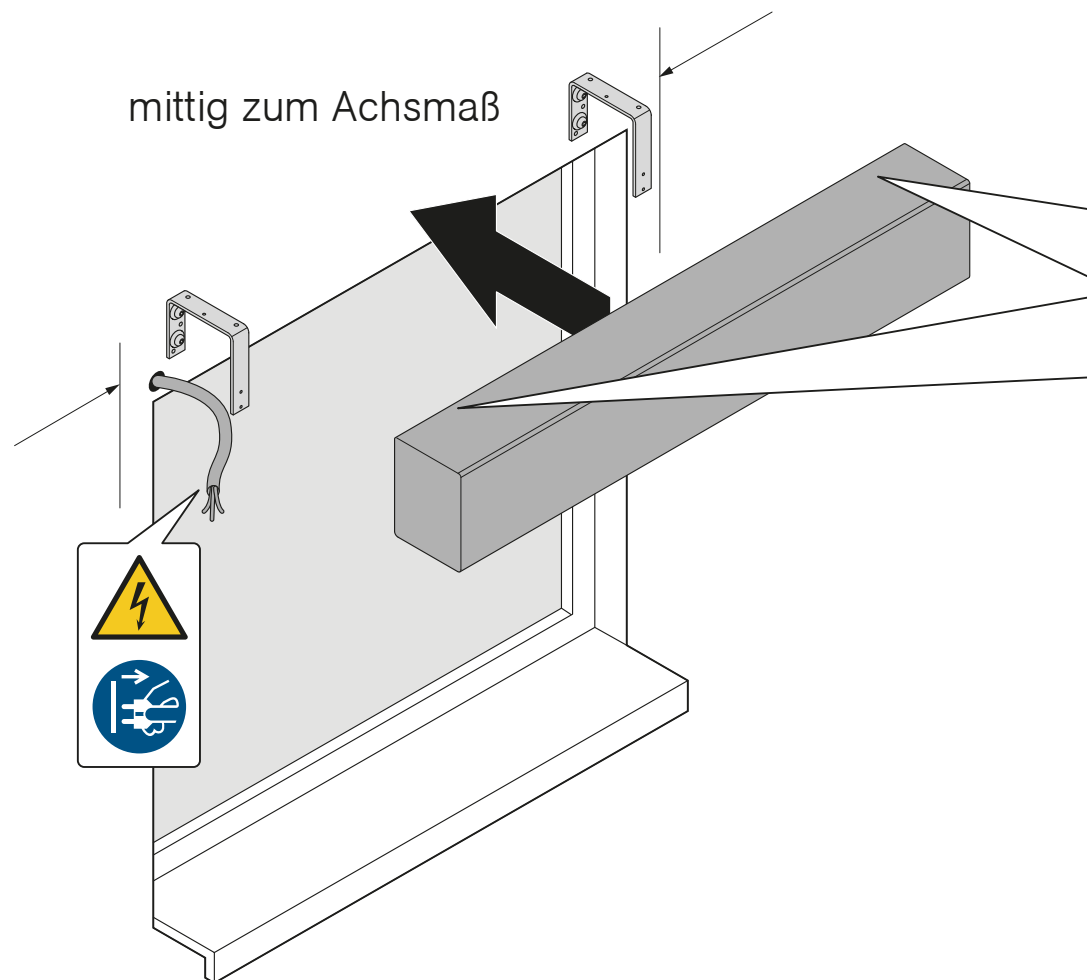

# Versteifungsbügel befestigen

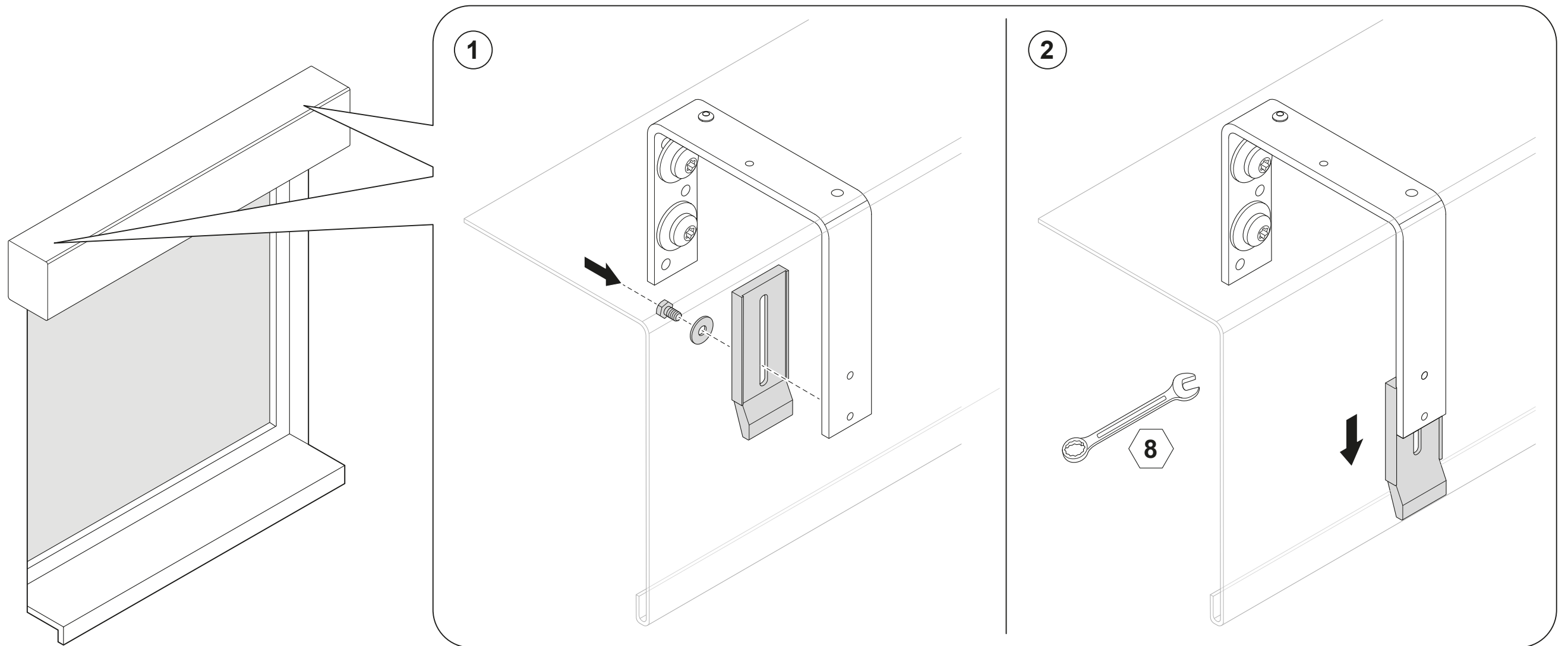

# Oberschienenenträger an Versteifungsbügel schrauben

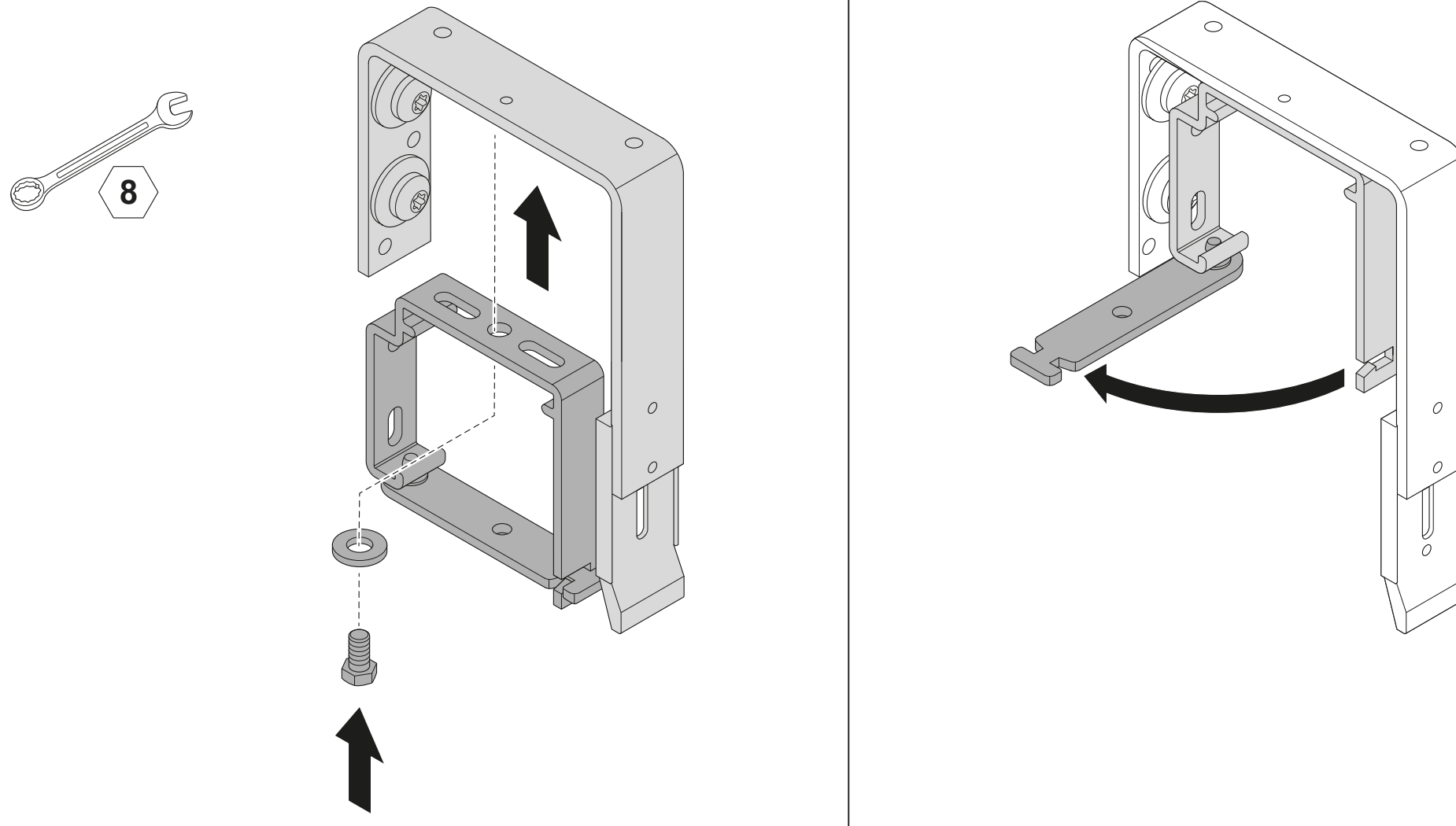

# Versteifungsbügel und Bohrung für Kabel auf Blende anzeichnen



B: siehe Seite 10 ff.

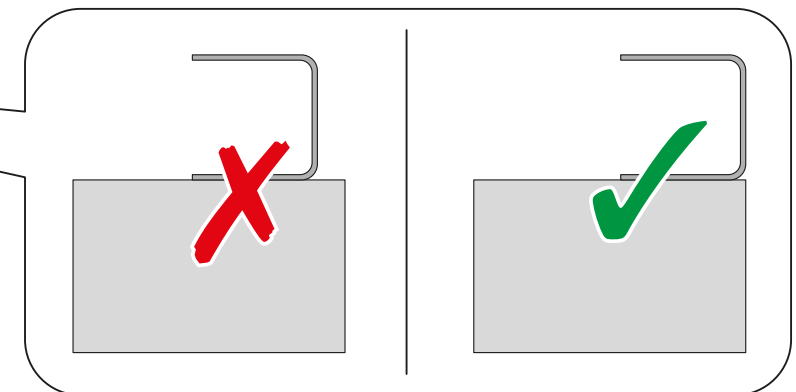
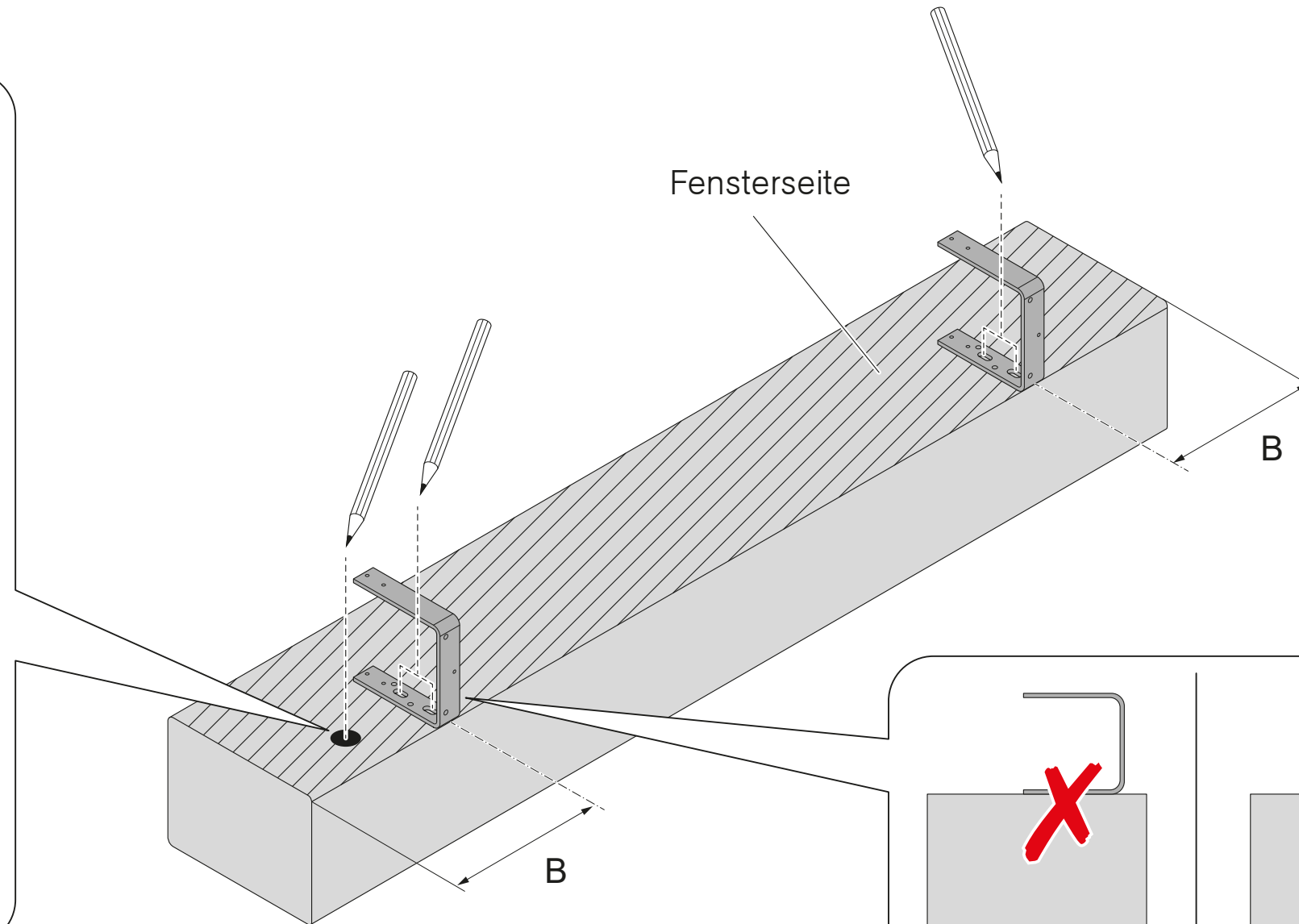
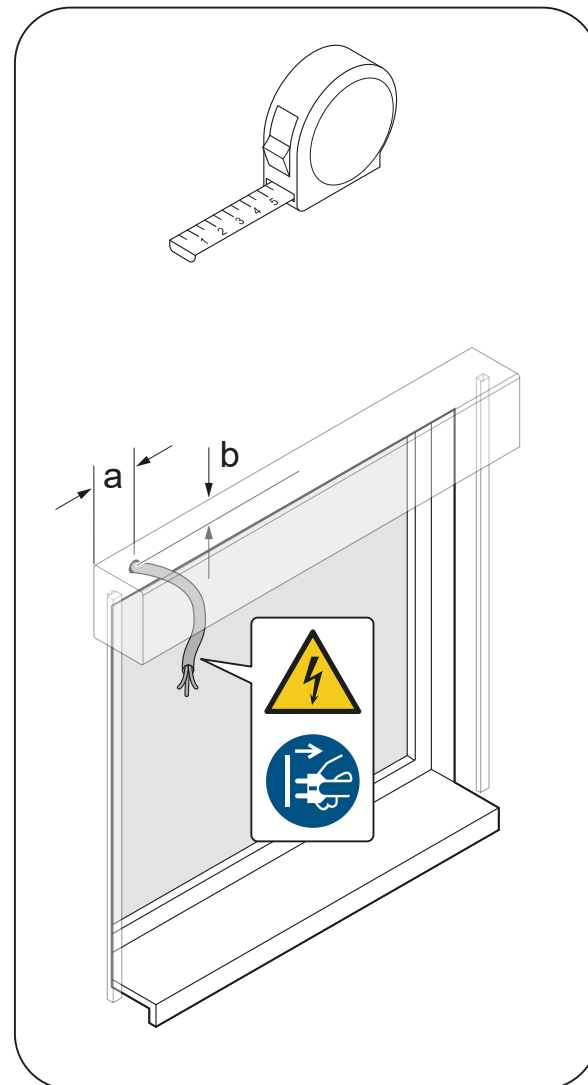



# Bohrungen für Versteifungsbügel und Kabel

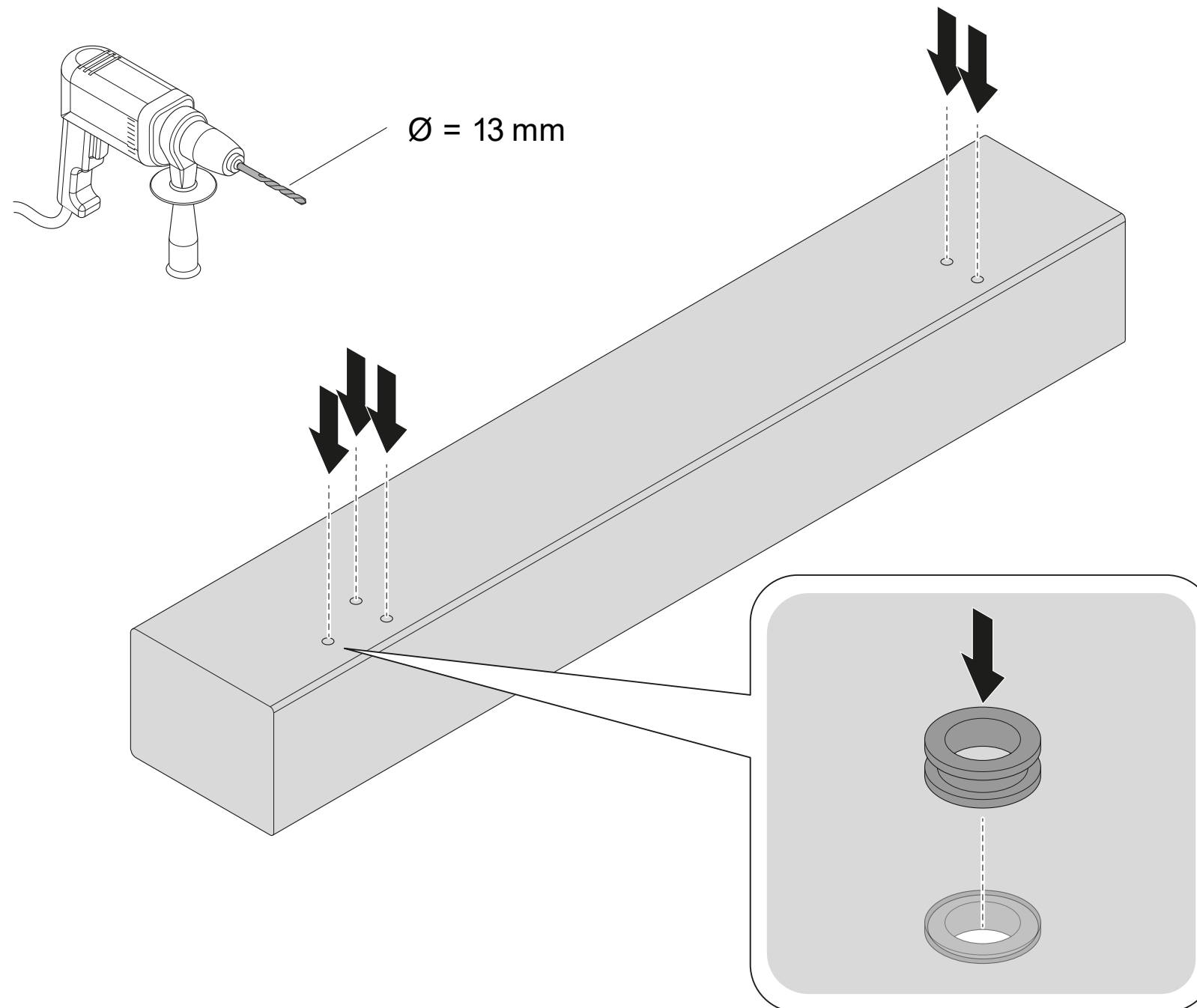

## Versteifungsbügel anbringen

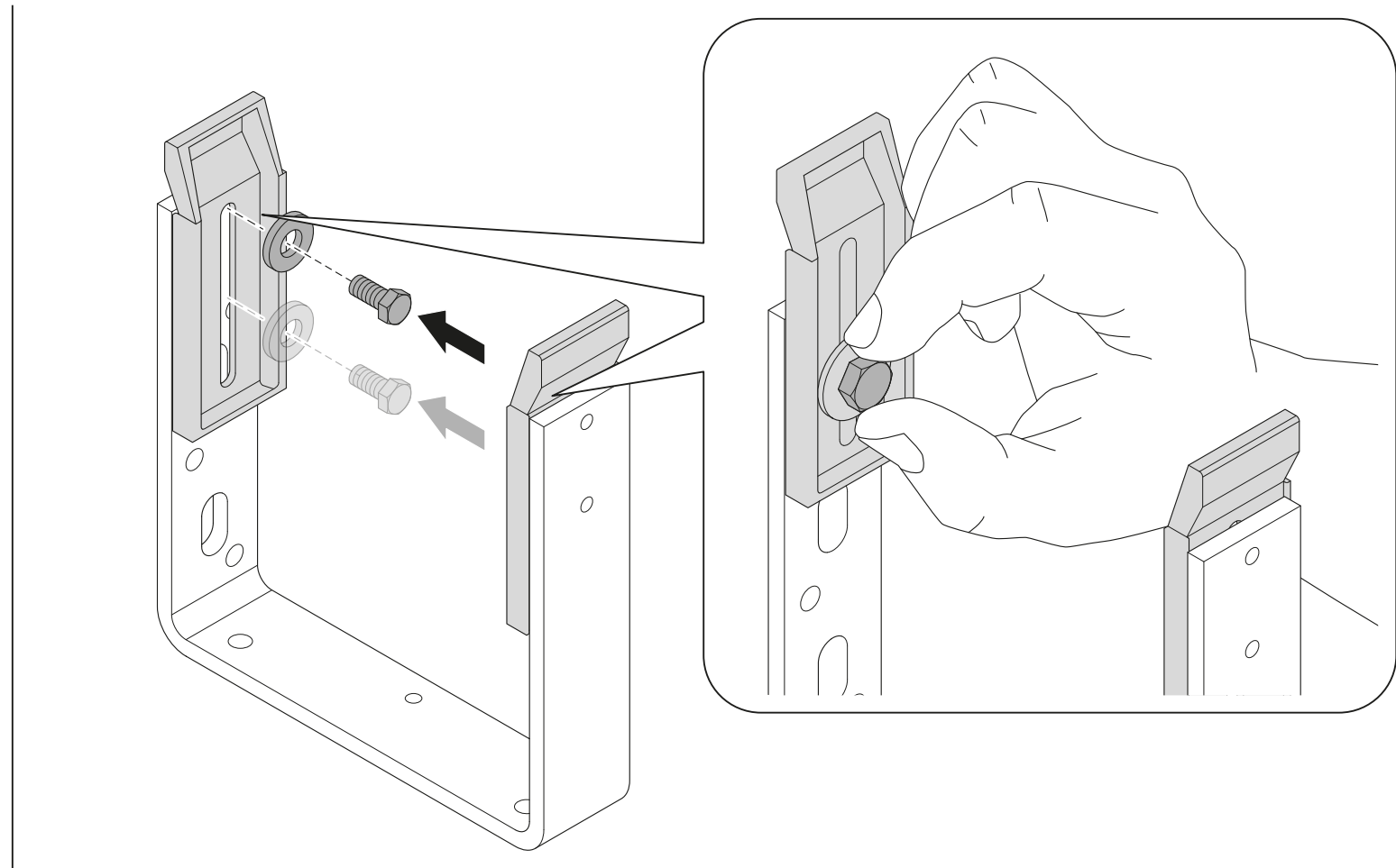
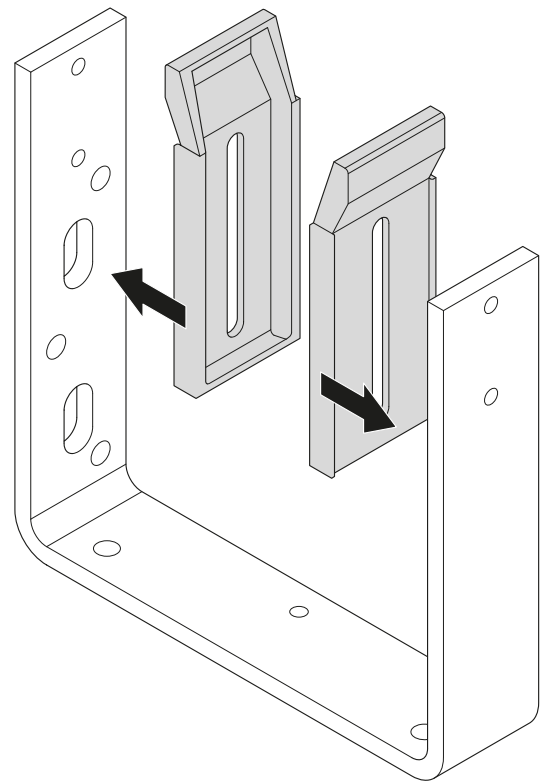

## Versteifungsbügel anbringen

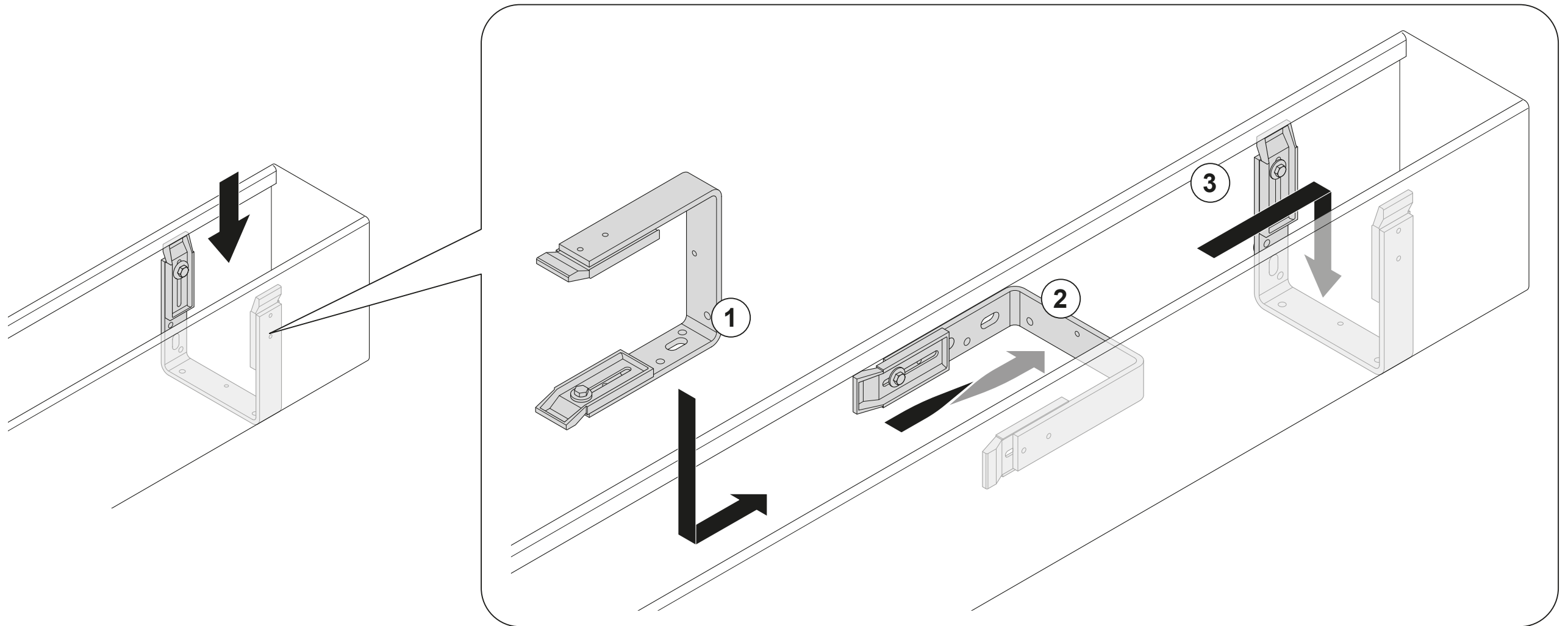

## Versteifungsbügel anbringen

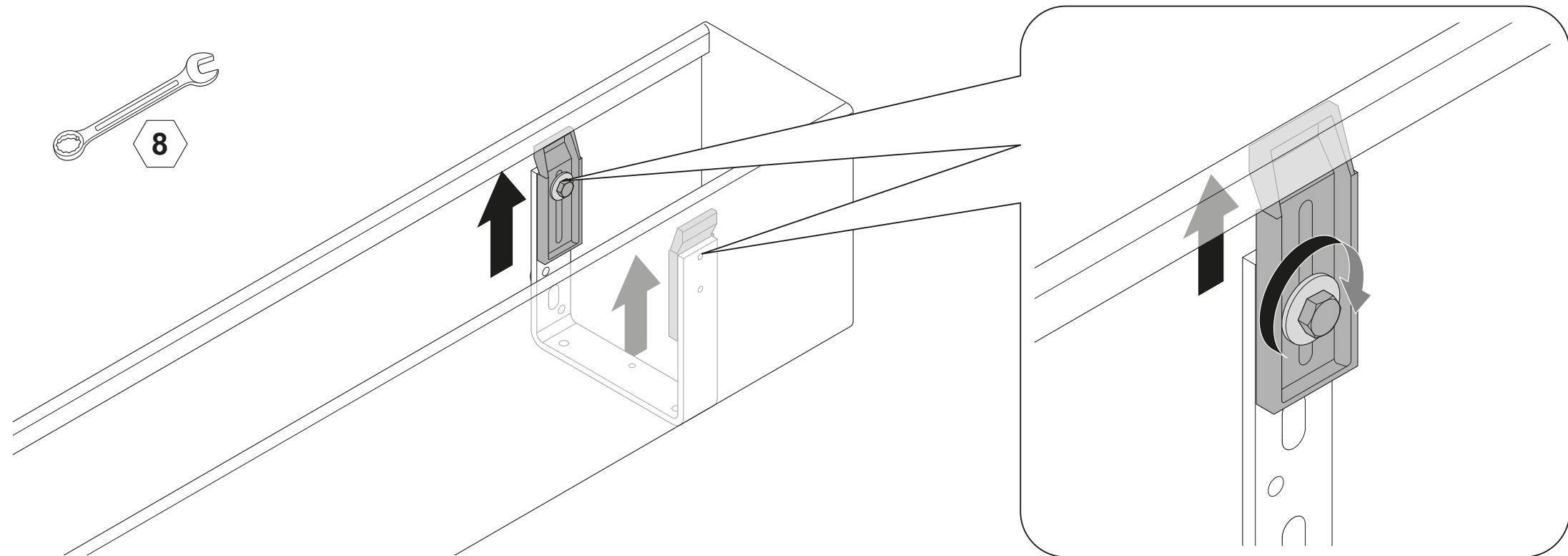

# Blende auf Montageuntergrund mittig zum Achsmaß befestigen



Auf sorgfältige Kabelführung achten. Keine Schlaufen im Antriebs- und Behangbereich. Kabel nicht knicken.

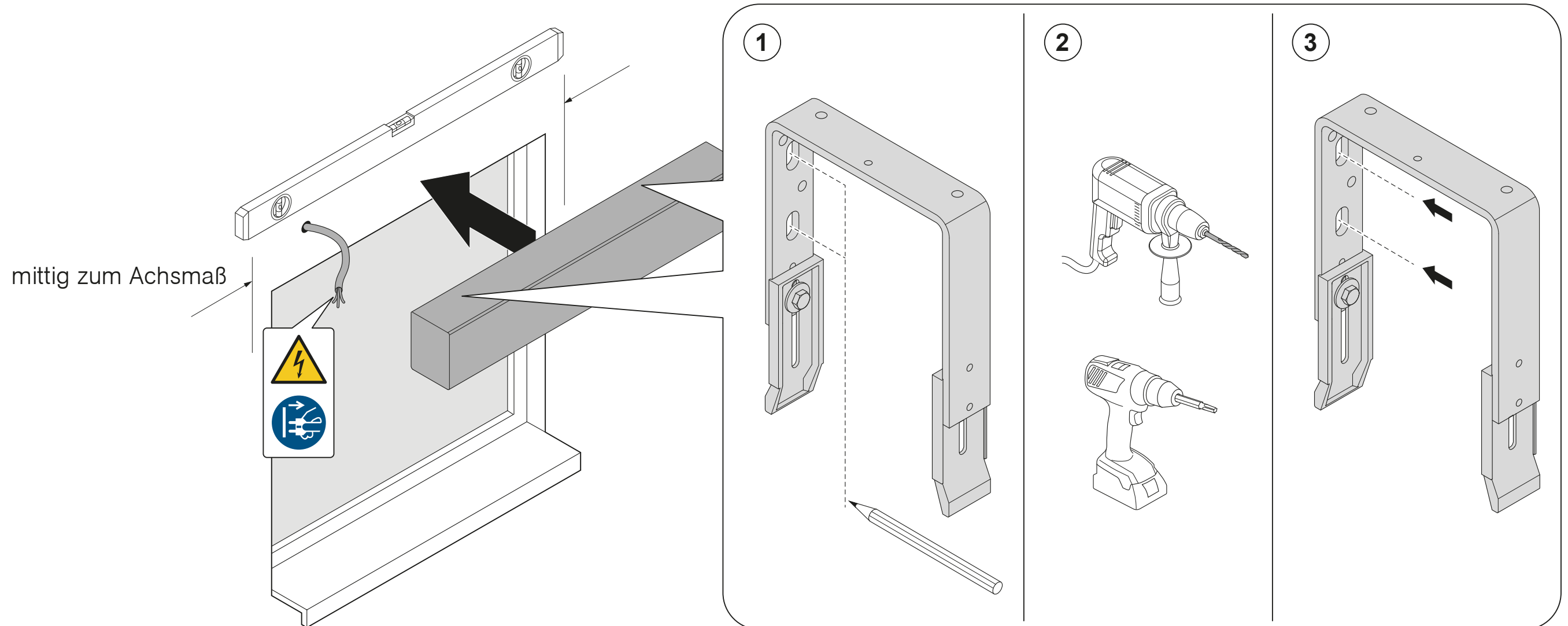

# Oberschienenenträger an Blende/Versteifungsbügel schrauben

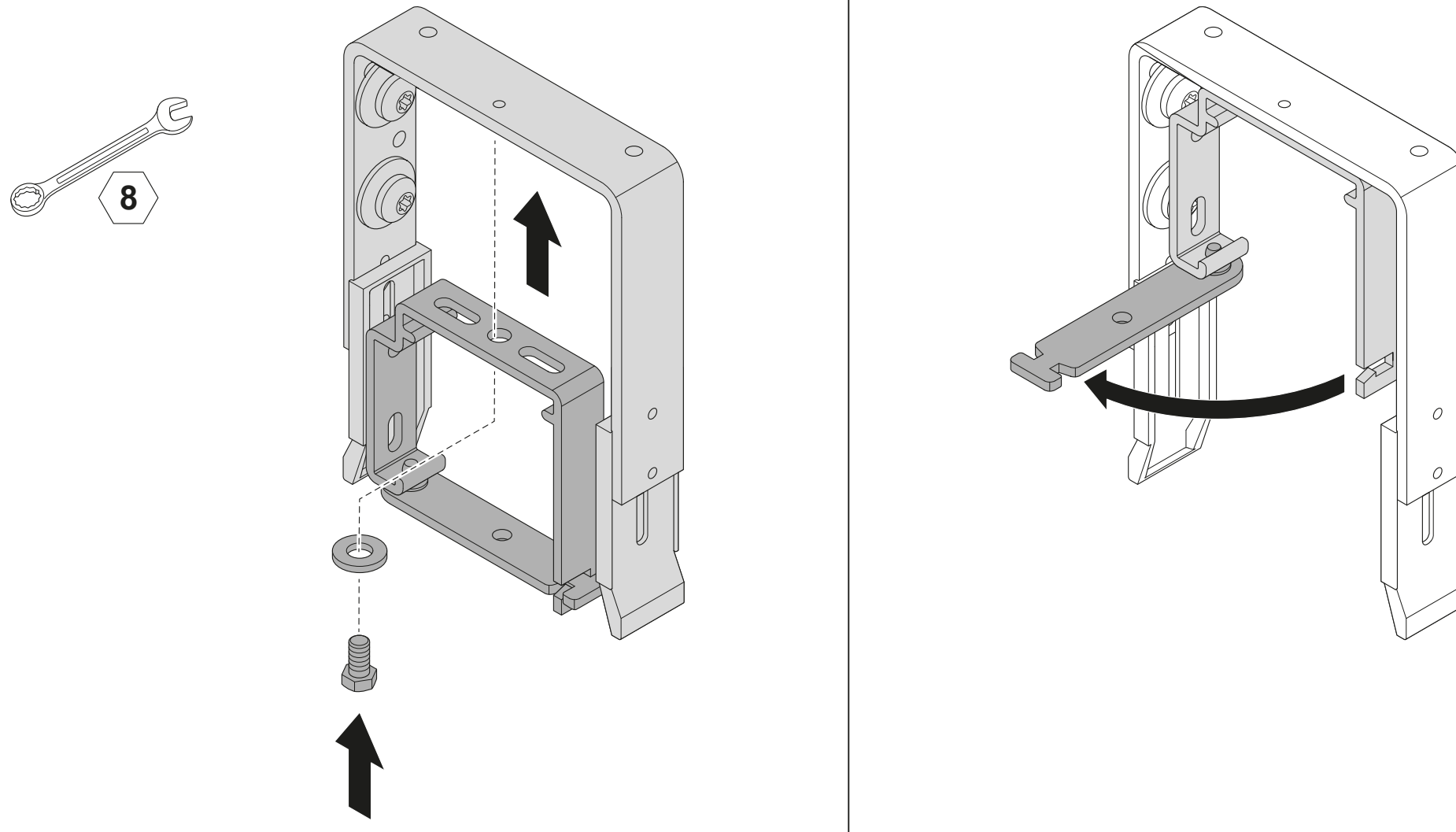

# 3

## Raffstorepaket einhängen

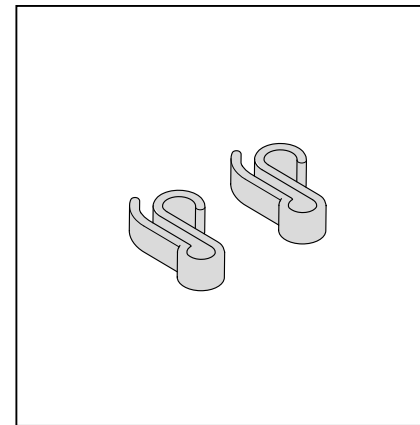
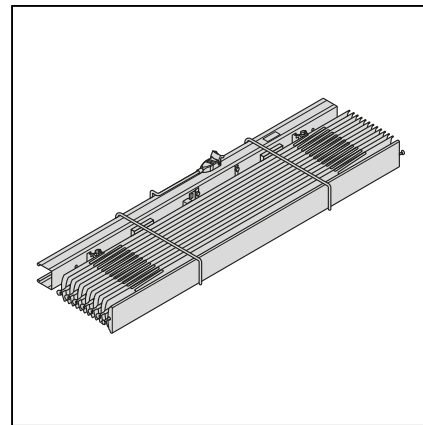

# Oberschiene und Raffstore vorbereiten

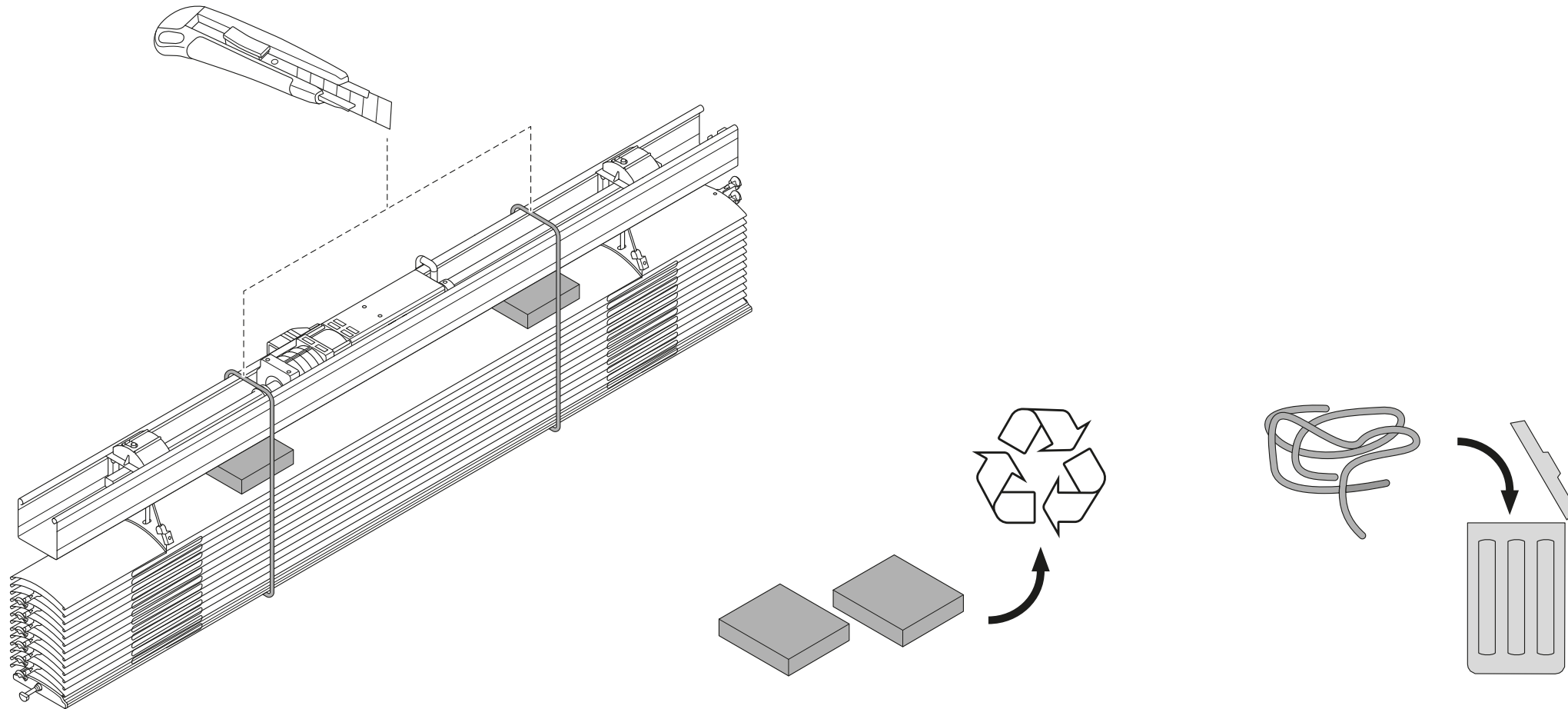



# Oberschiene und Raffstore vorbereiten



Fenster- bzw. Wandseite beachten

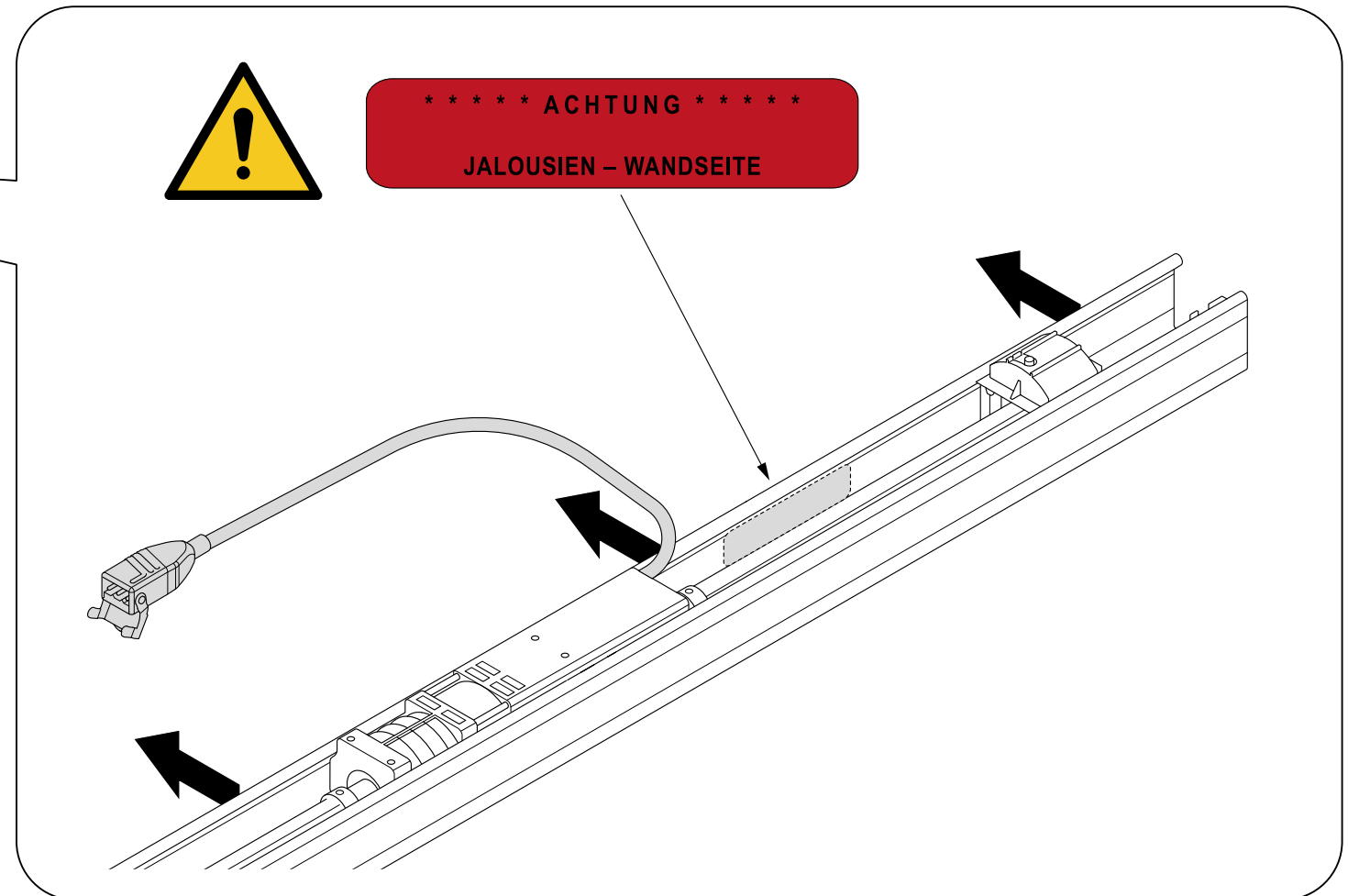
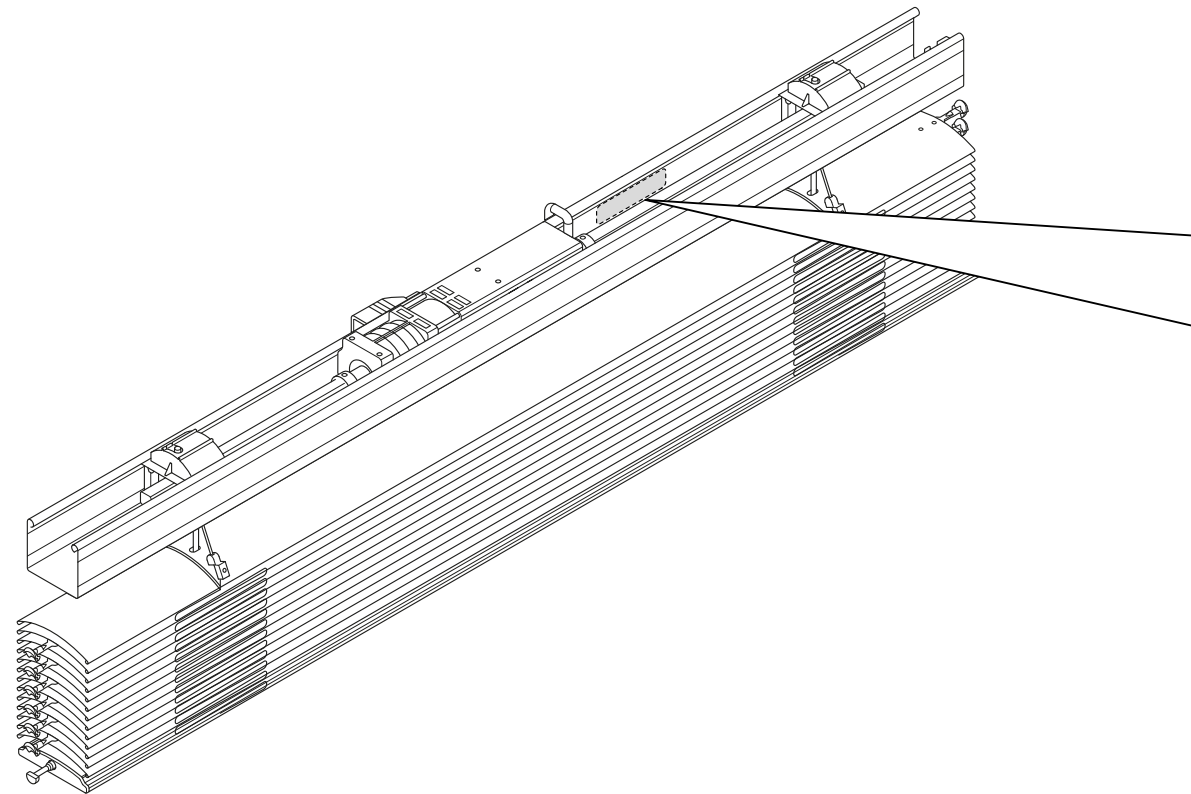

## Oberschiene und Raffstore vorbereiten

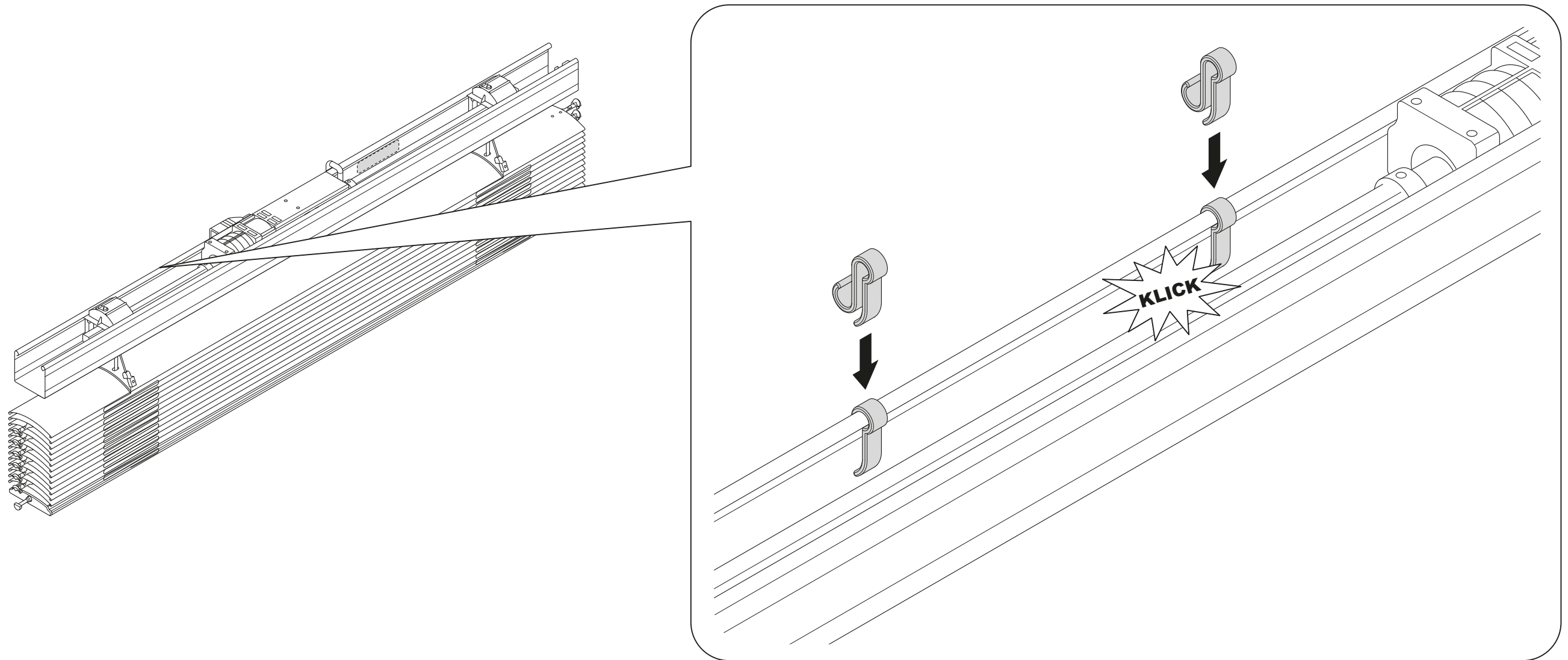

# Oberschiene mit Raffstore in Oberschienenenträger mittig einhängen

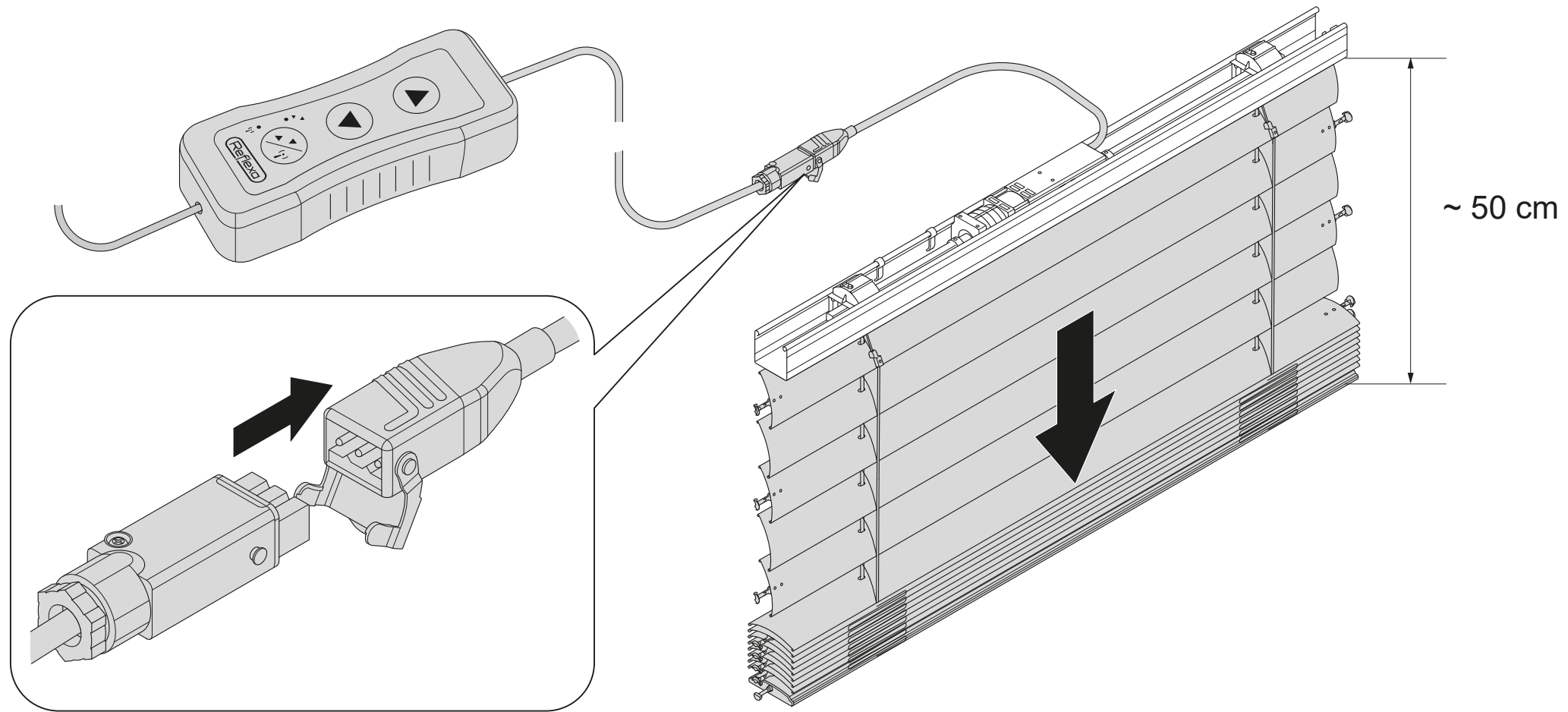

# Oberschiene mit Raffstore in Oberschienenenträger mittig einhängen

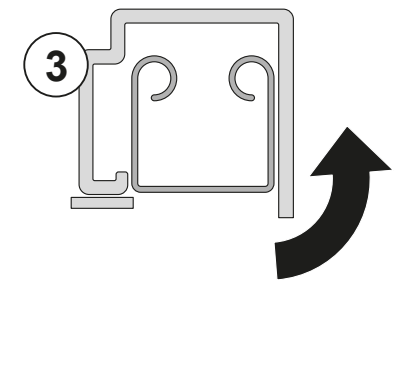
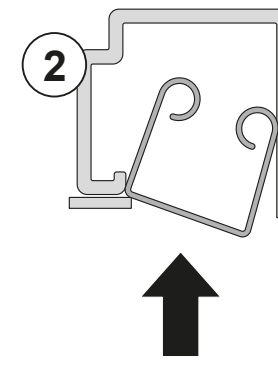
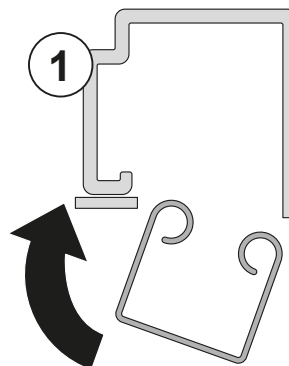
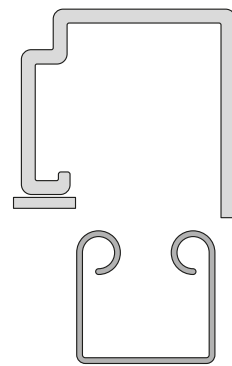
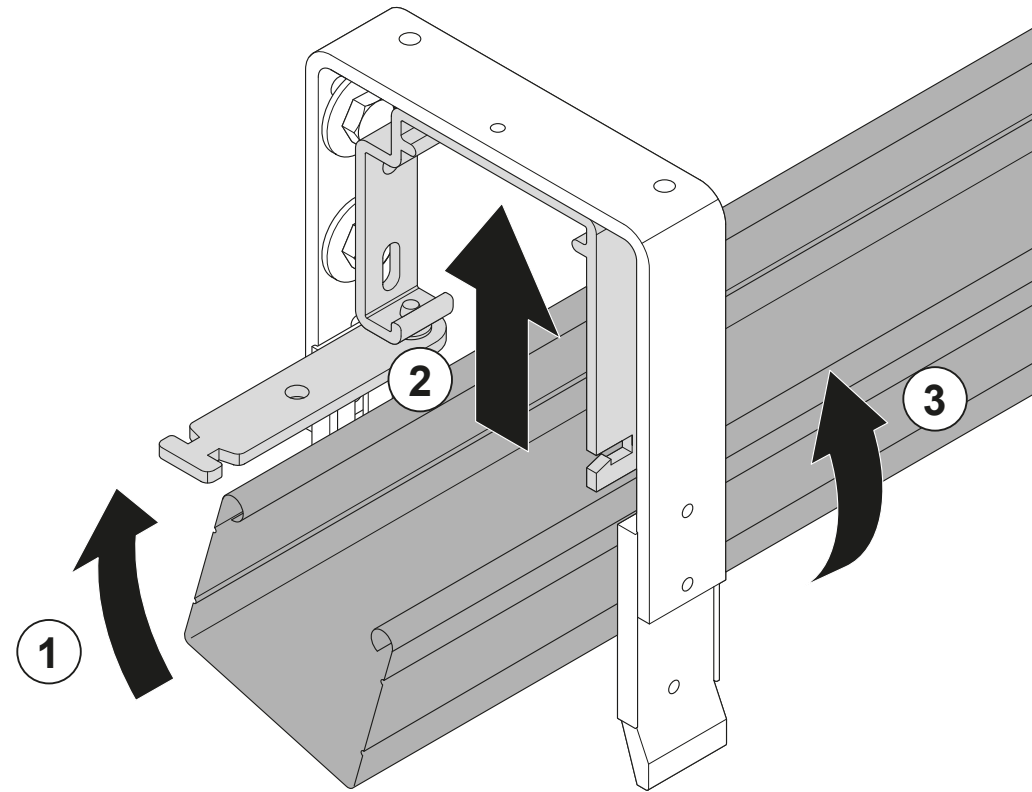
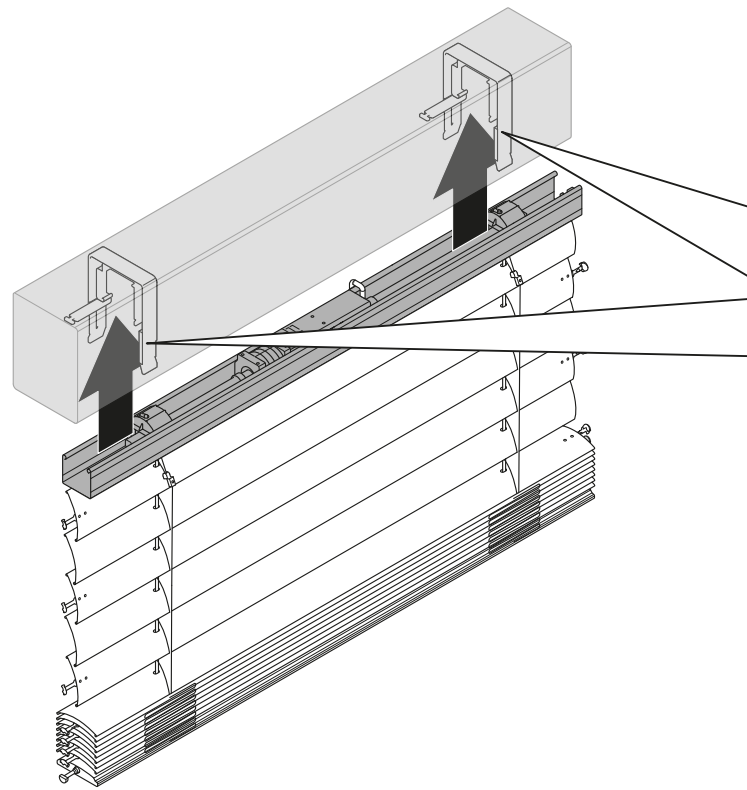

# Oberschiene mit Raffstore in Oberschienenenträger mittig einhängen

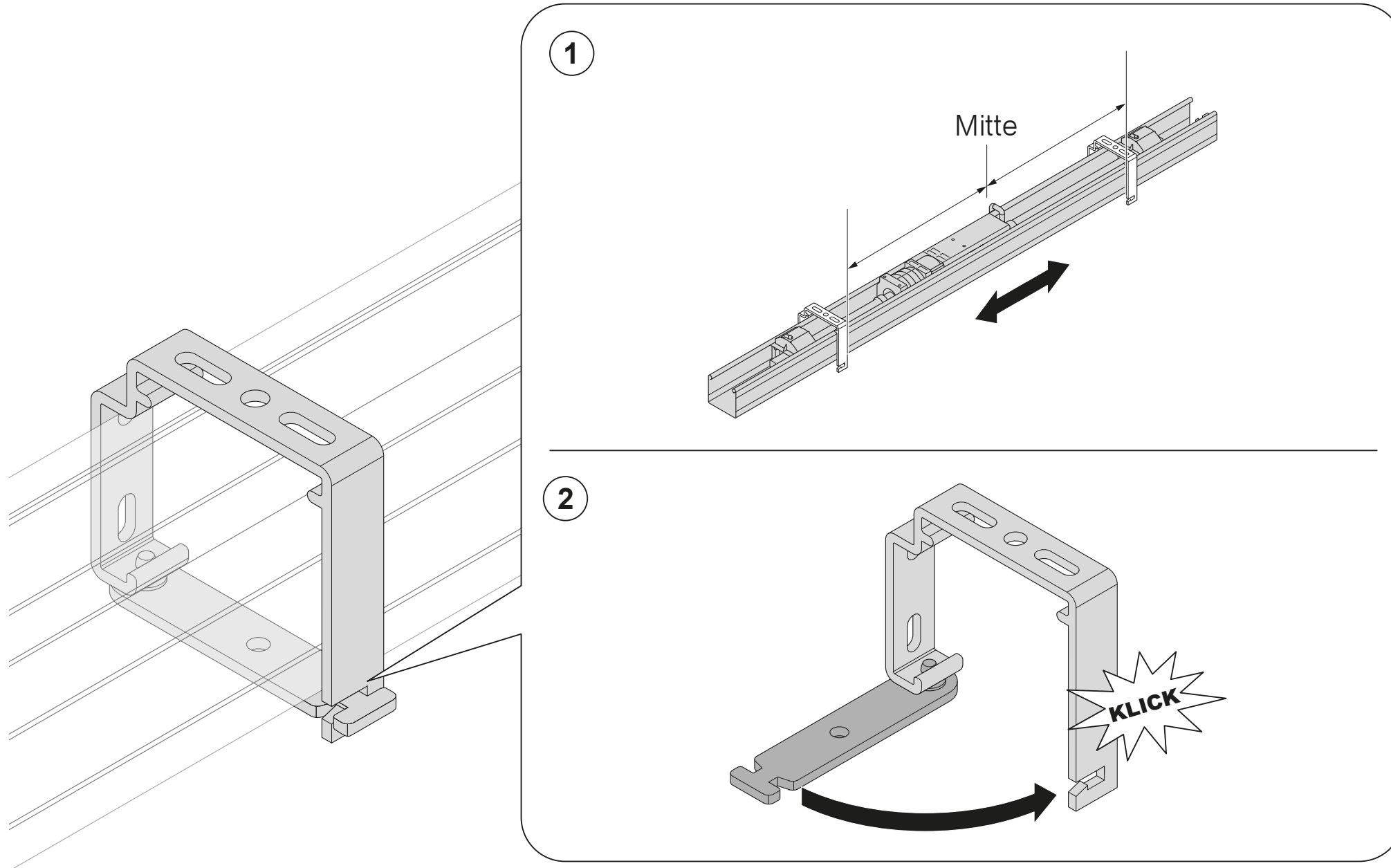

## Optional: Behangkopplung

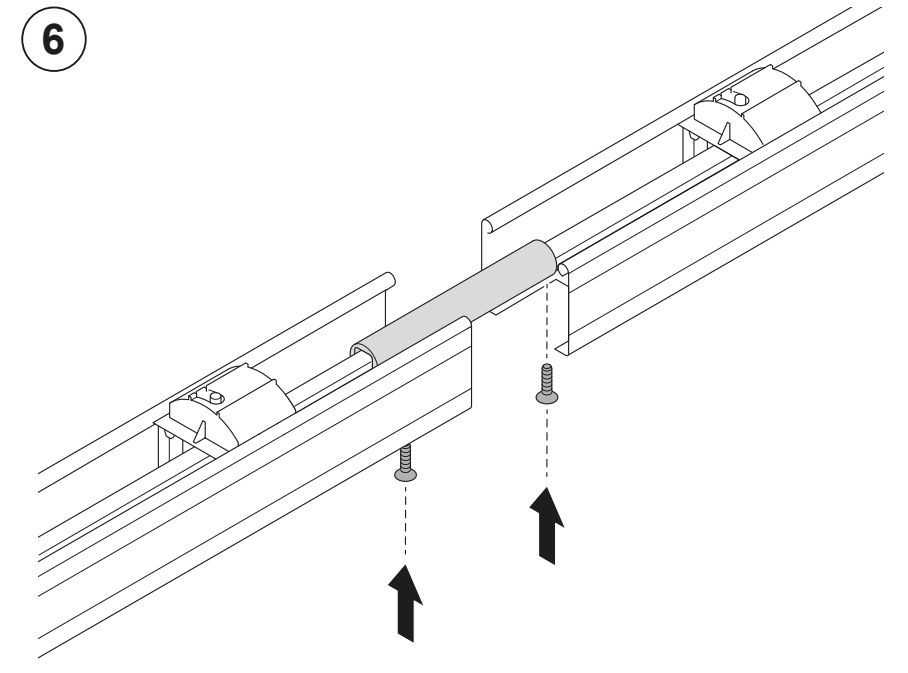
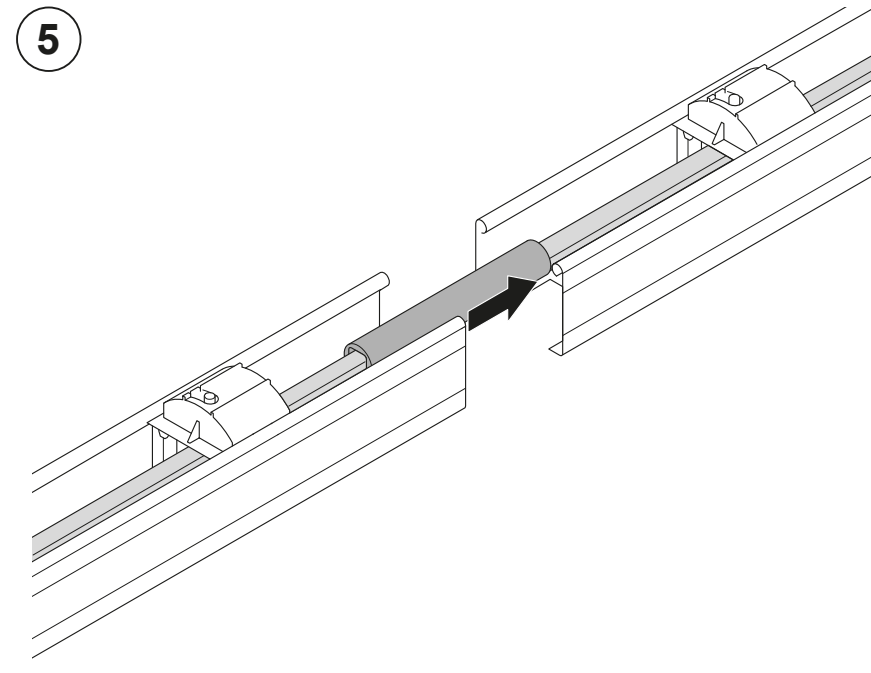
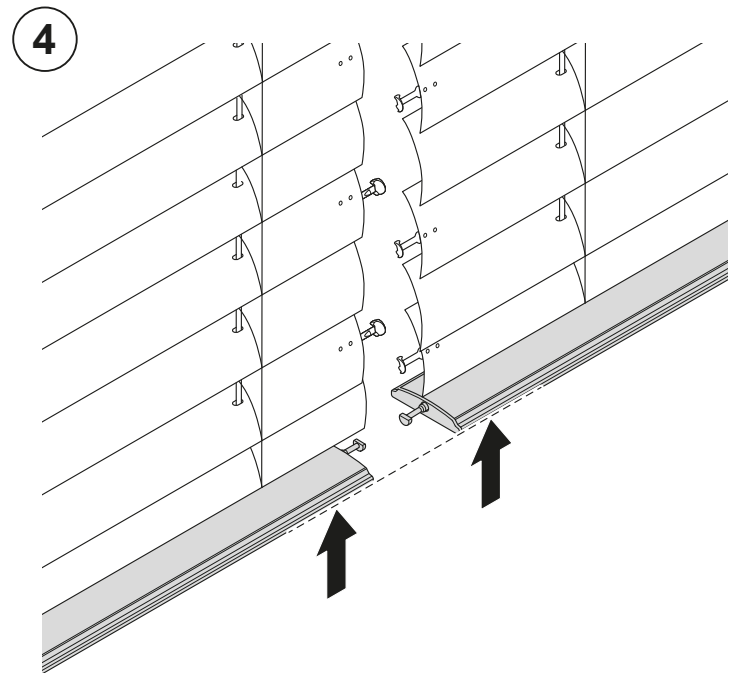
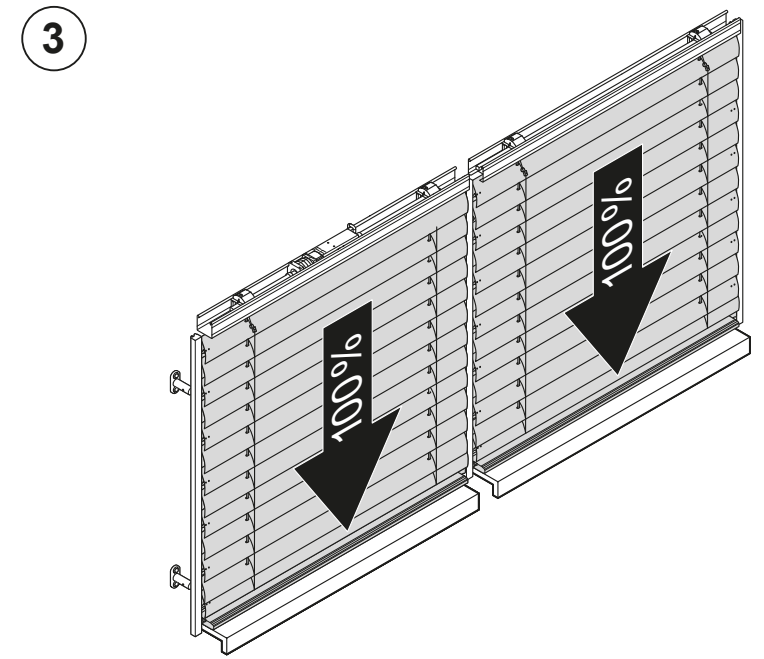
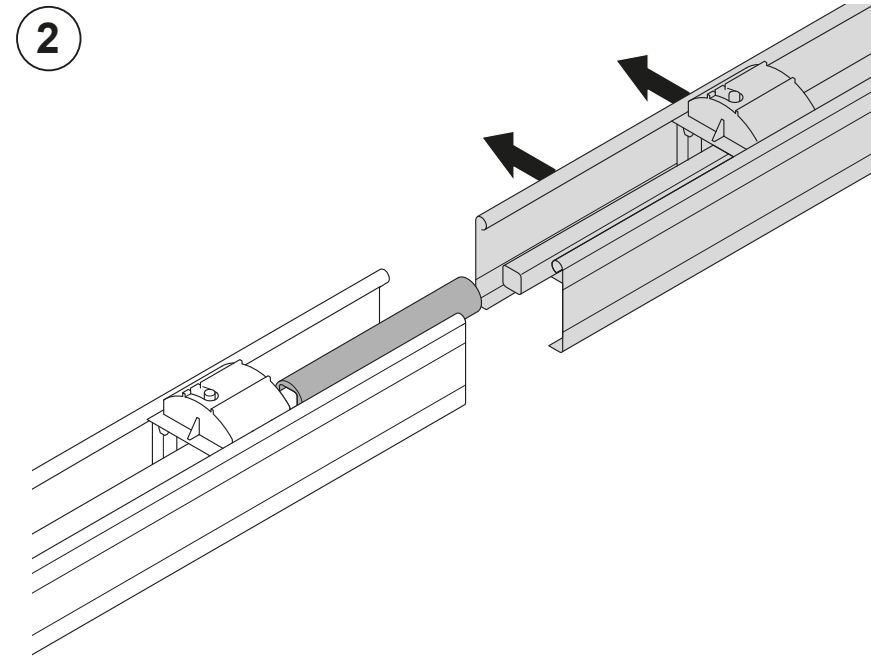
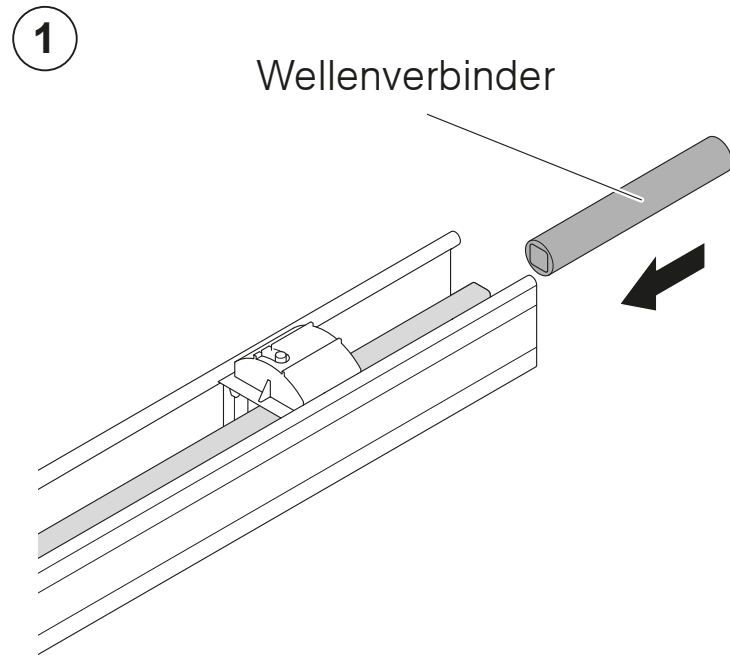

# 4

## Führungsschiene befestigen

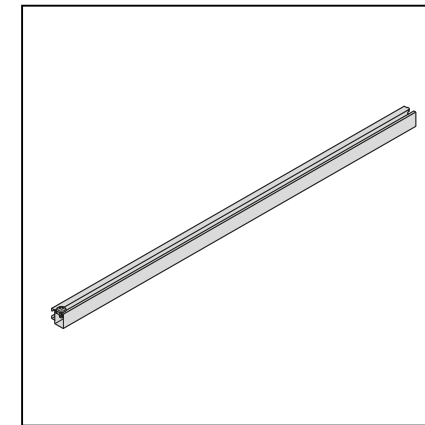
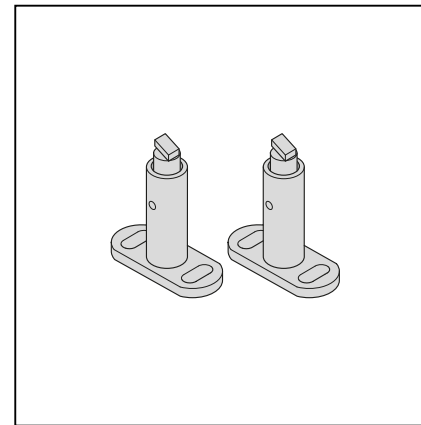
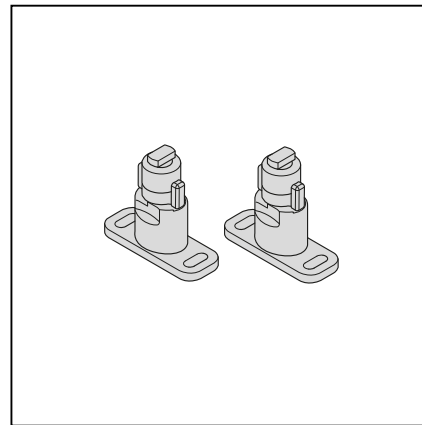

# Abstandshalter auf Montageuntergrund befestigen

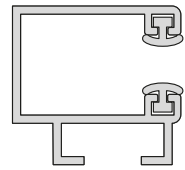

Typ T

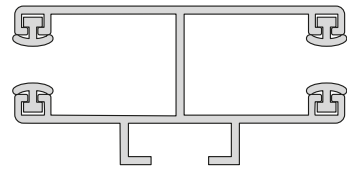

Typ D

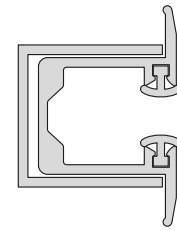

Typ P

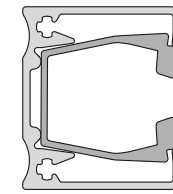

Typ E30

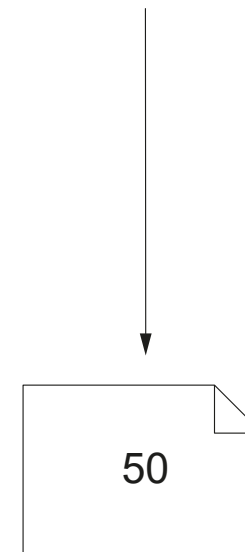
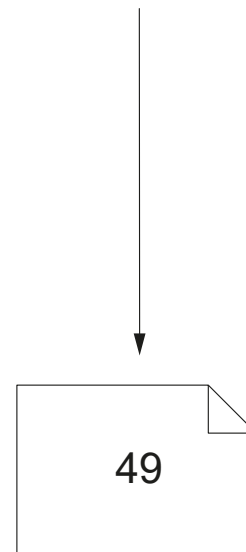
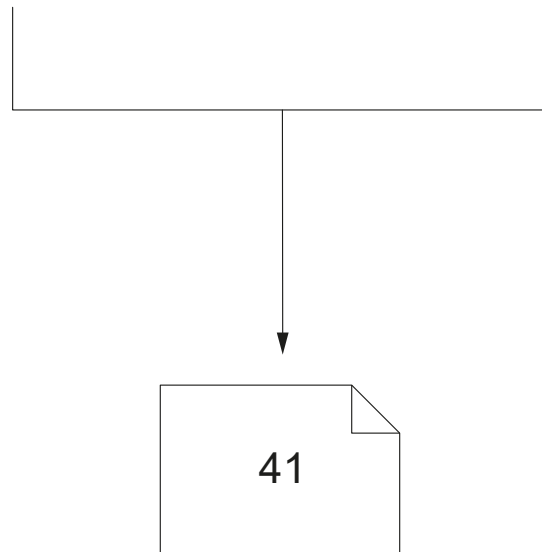



# Abstandshalter auf Montagegrund befestigen, Profil Typ T/Typ D

Raffstorehöhe	Anzahl Abstandshalter pro Führungsschiene
bis 2.000 mm	2 Stück
bis 3.000 mm	3 Stück
bis 4.000 mm	4 Stück
bis 5.000 mm	5 Stück

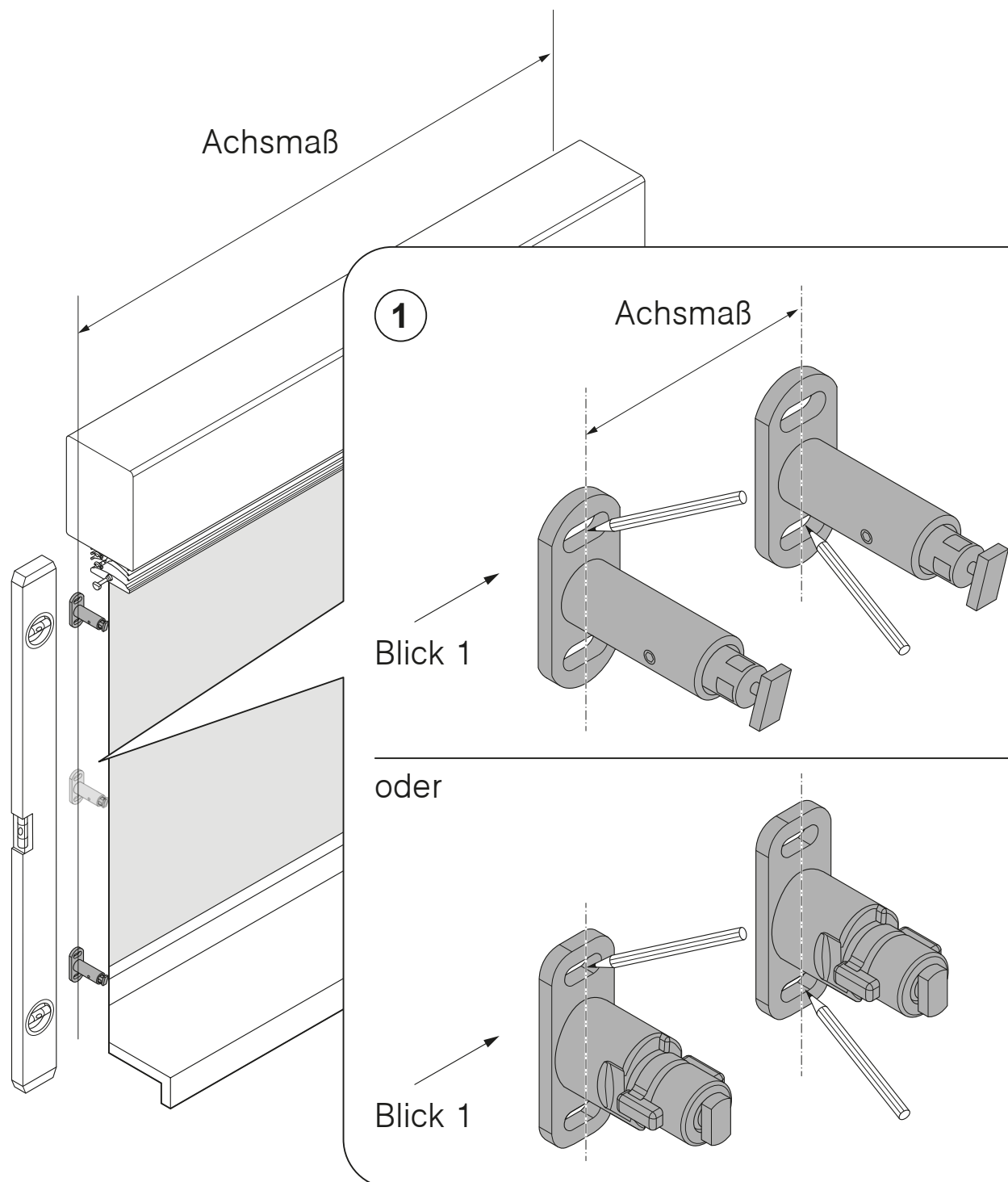

Blick 1

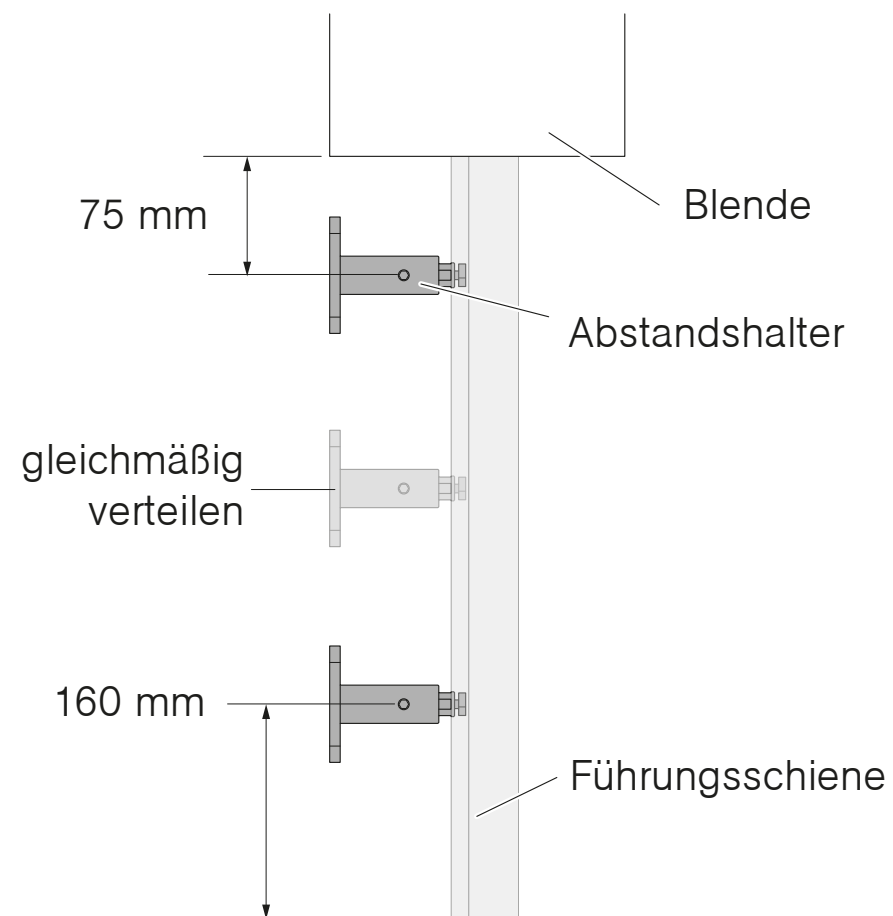

2

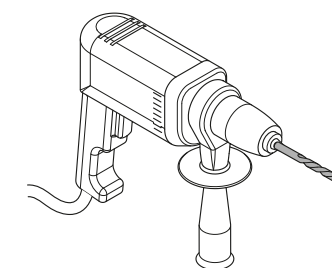

# Abstandshalter auf Montagegrund befestigen (nur Typ A/B/C)

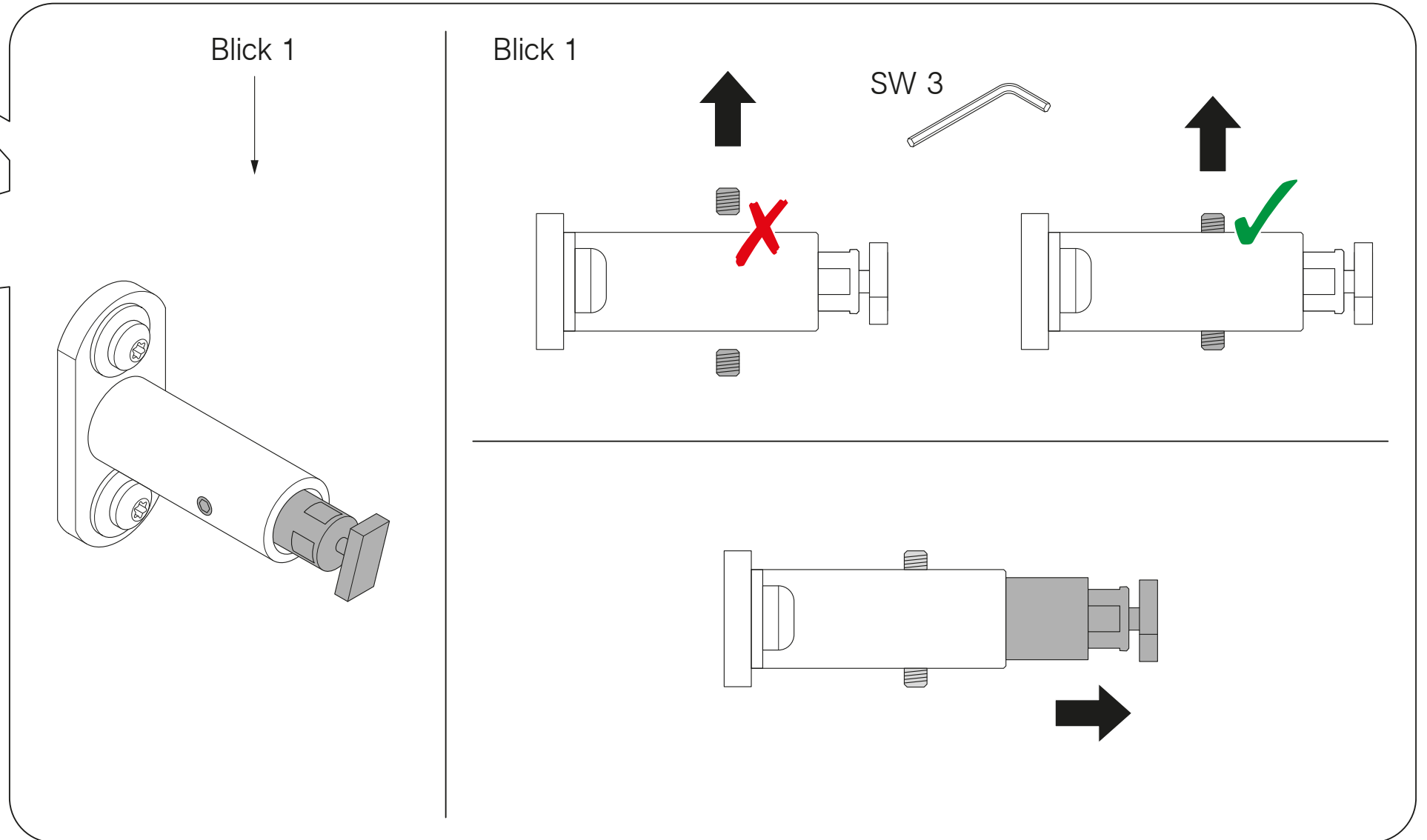
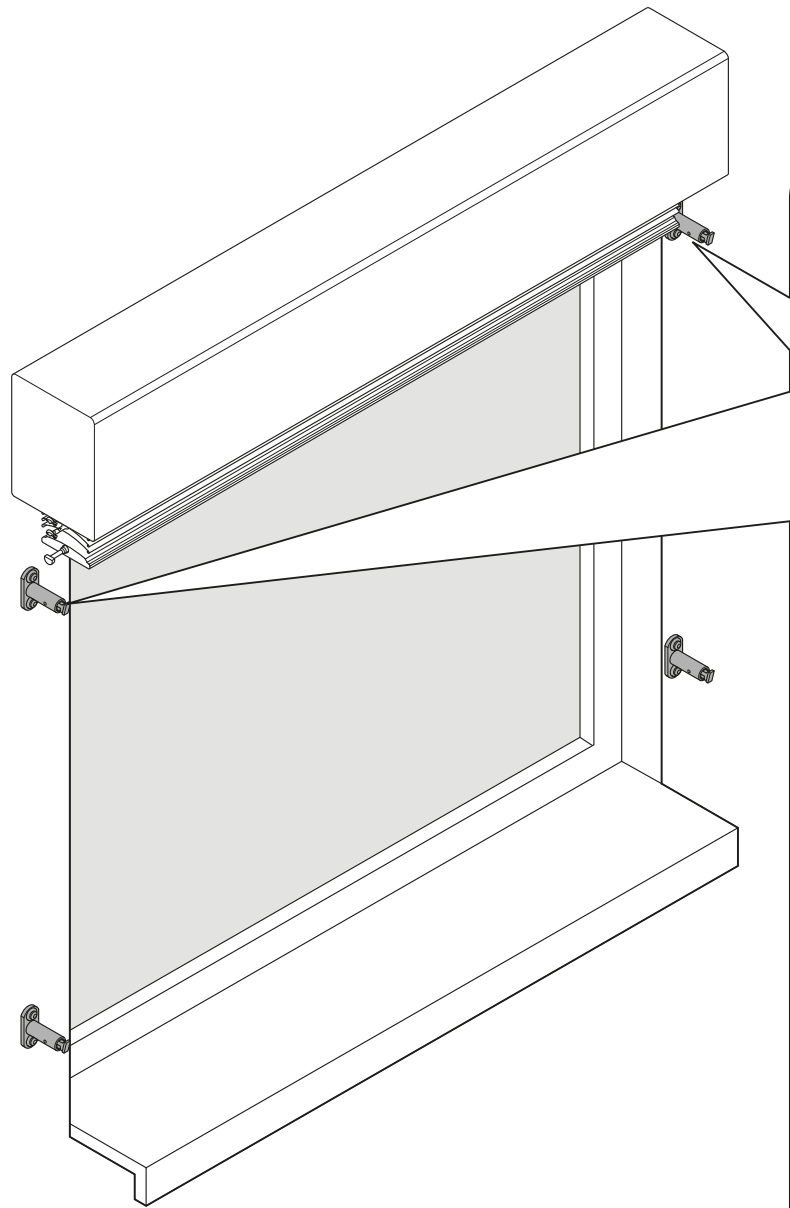

# Führungsschiene einsetzen

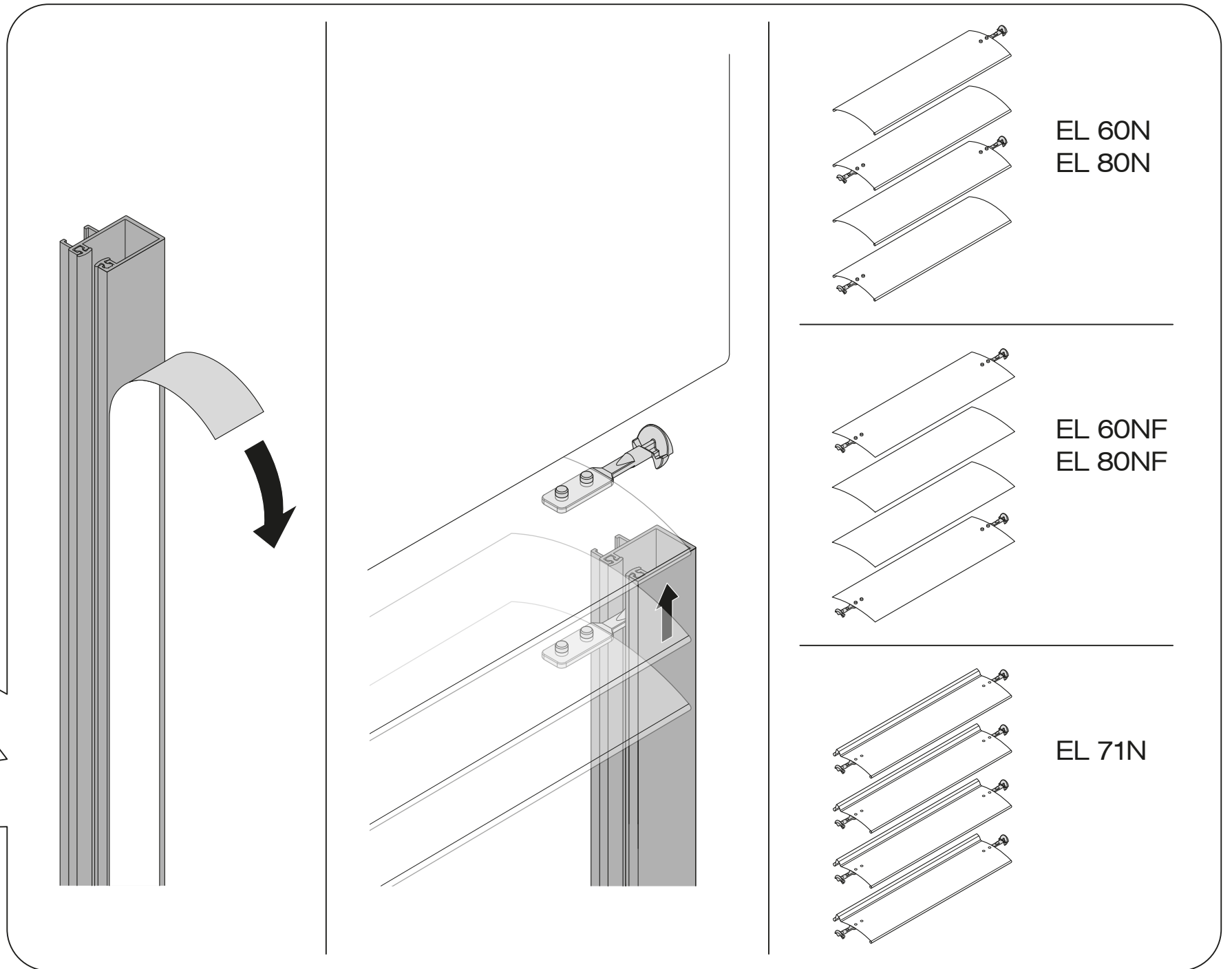
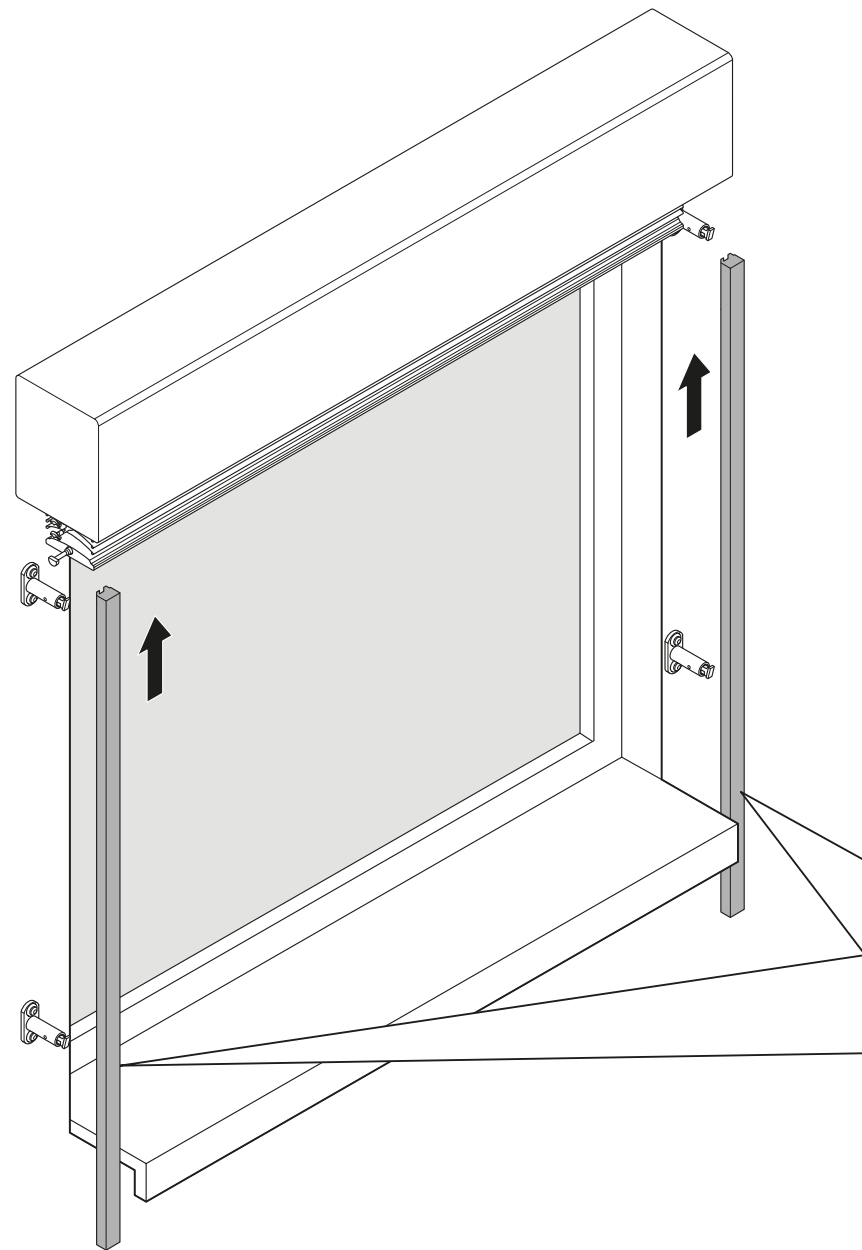

## Führungsschiene horizontal ausrichten (Abstandshalter Typ X70)

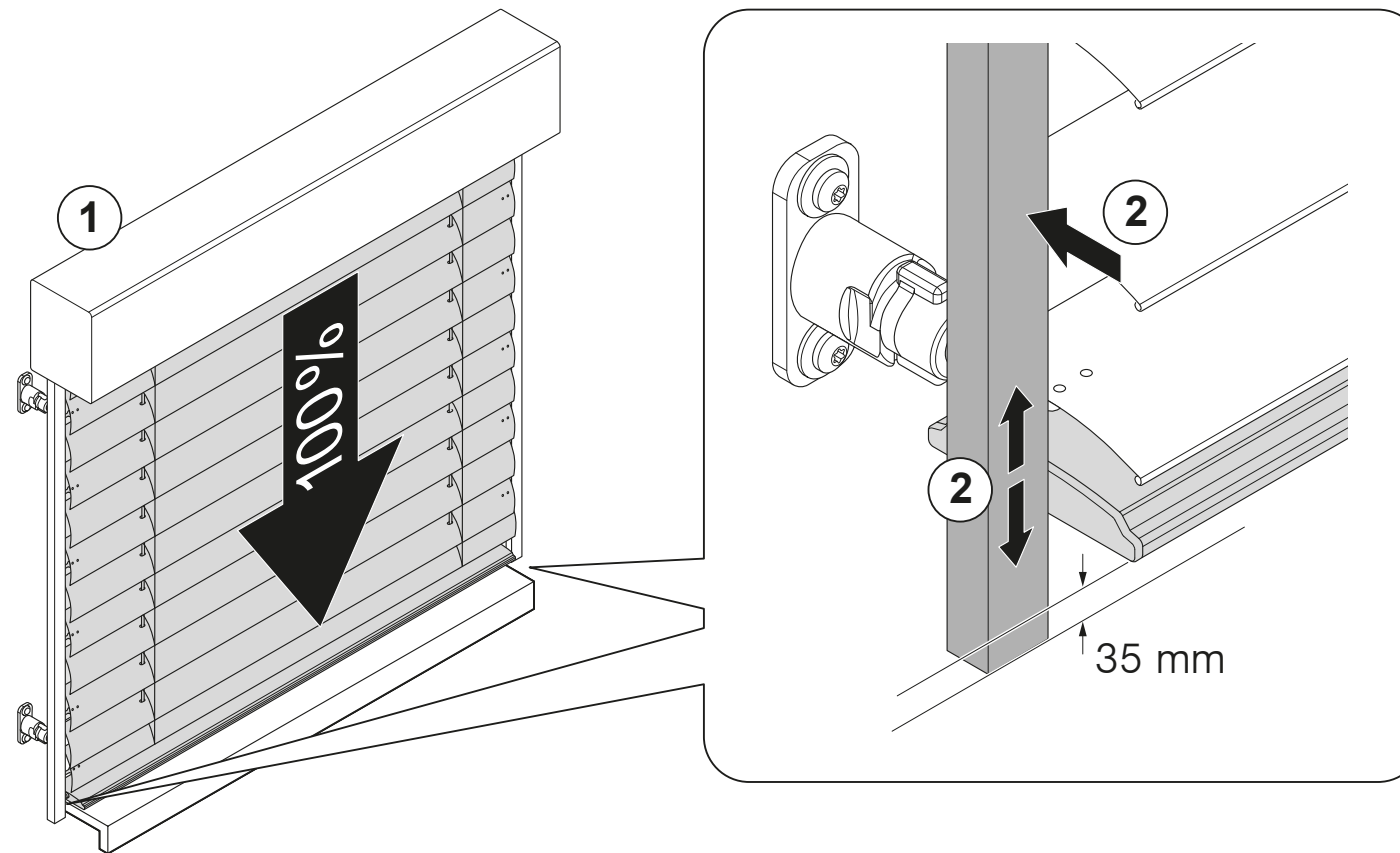

# Führungsschiene in Abstandshalter Typ X70 einsetzen

1

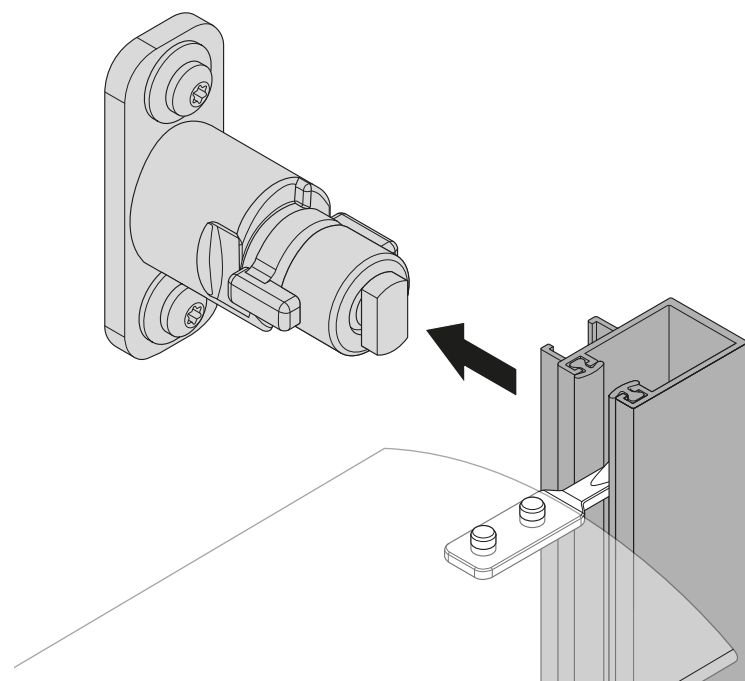

2

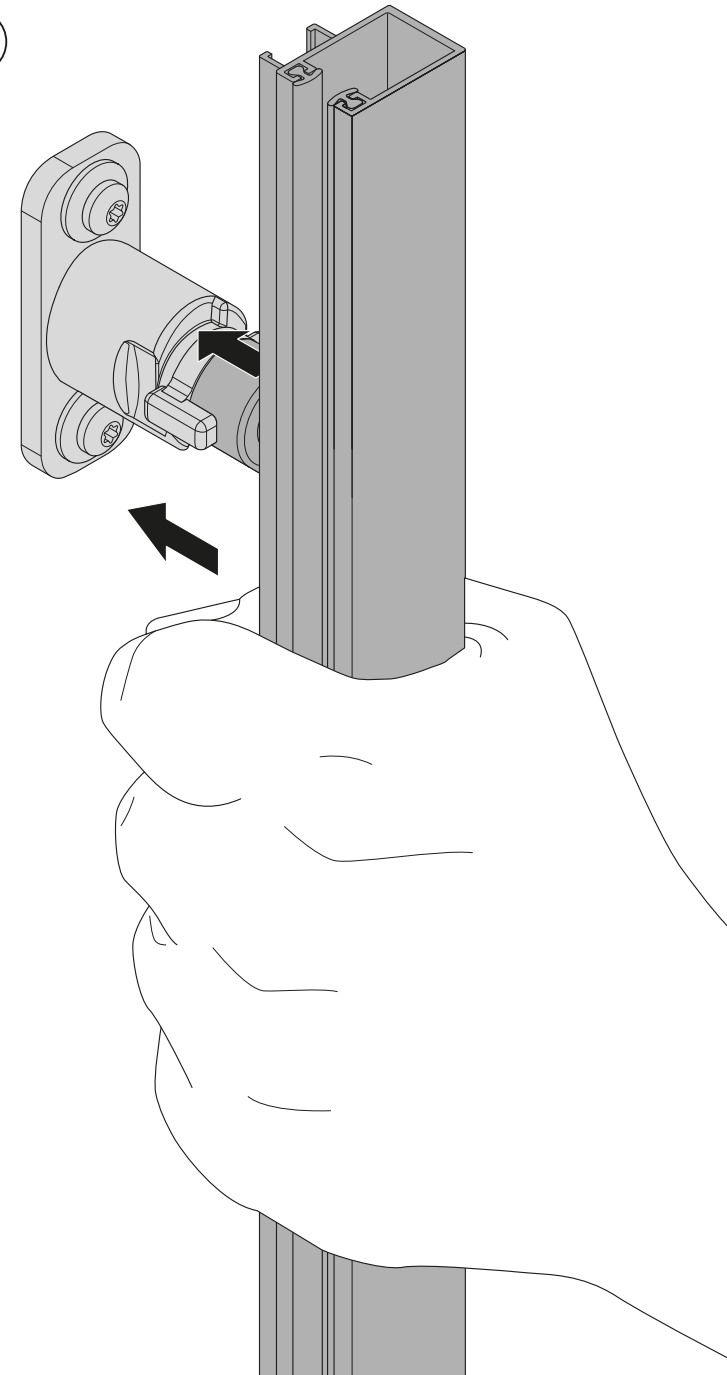

3

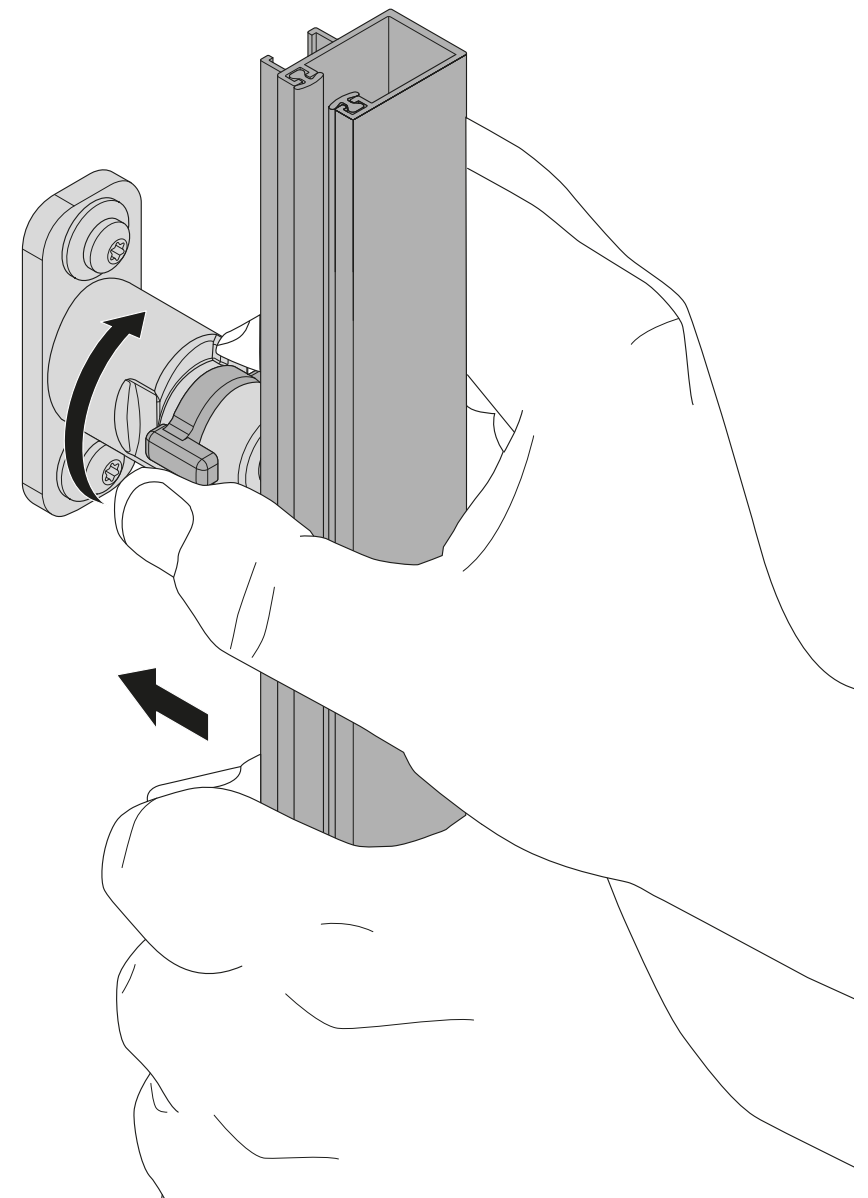

# Führungsschiene in Abstandshalter Typ A/B/C einsetzen

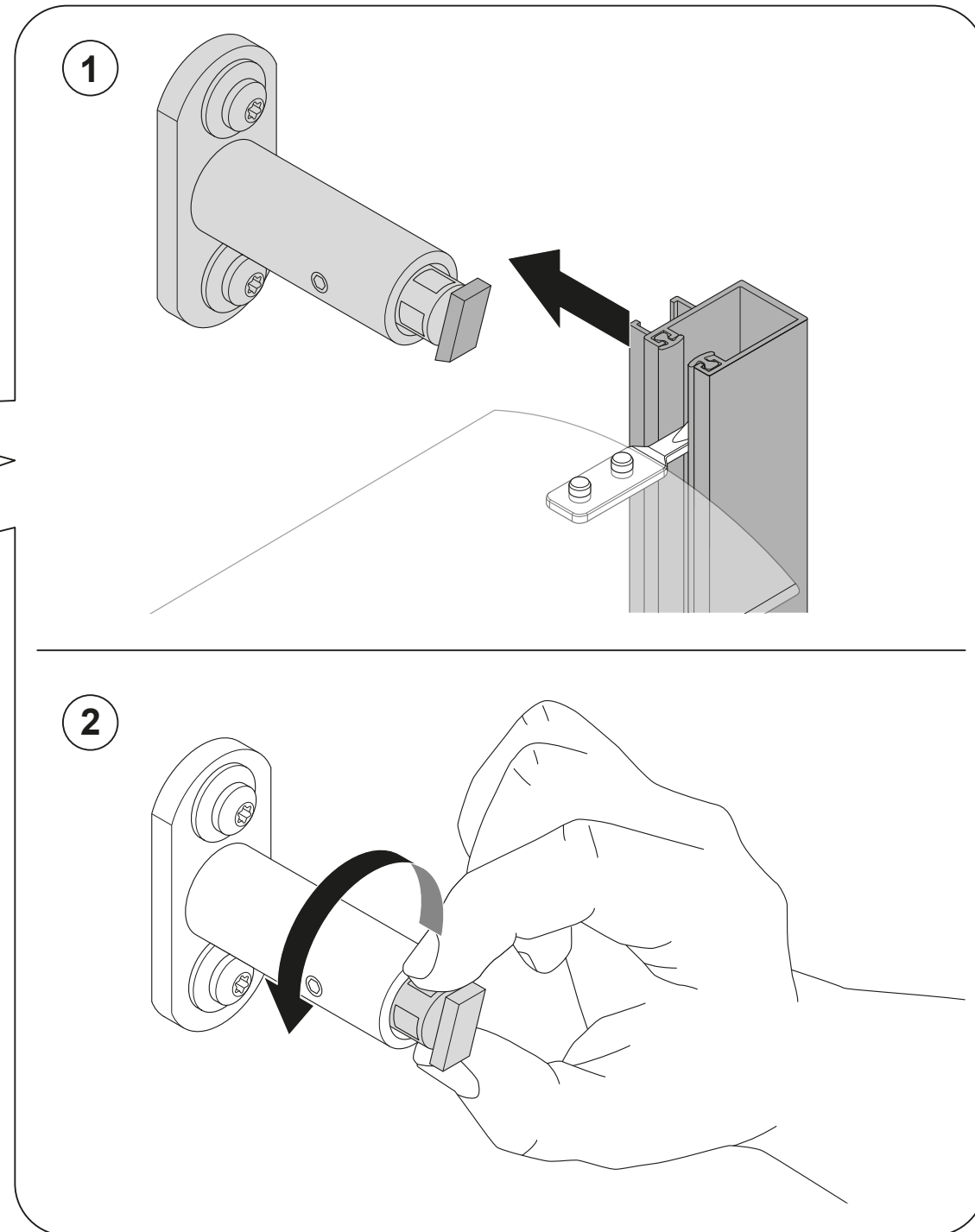
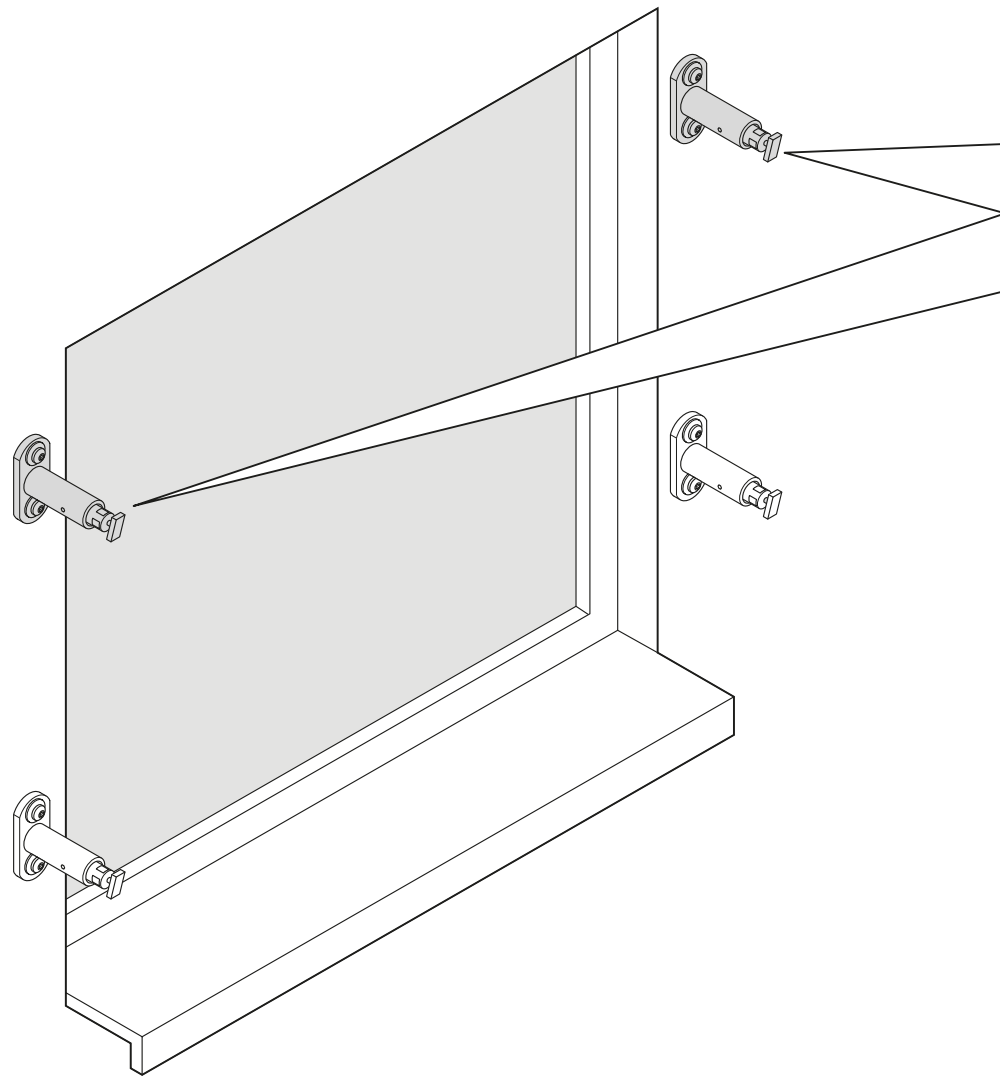

# Führungsschiene horizontal ausrichten (Abstandshalter Typ A/B/C)

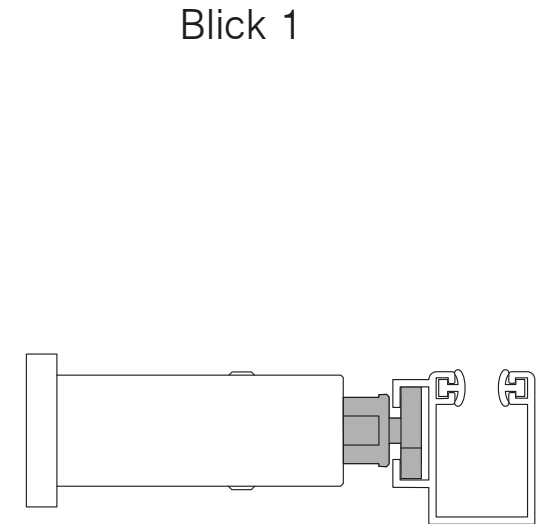
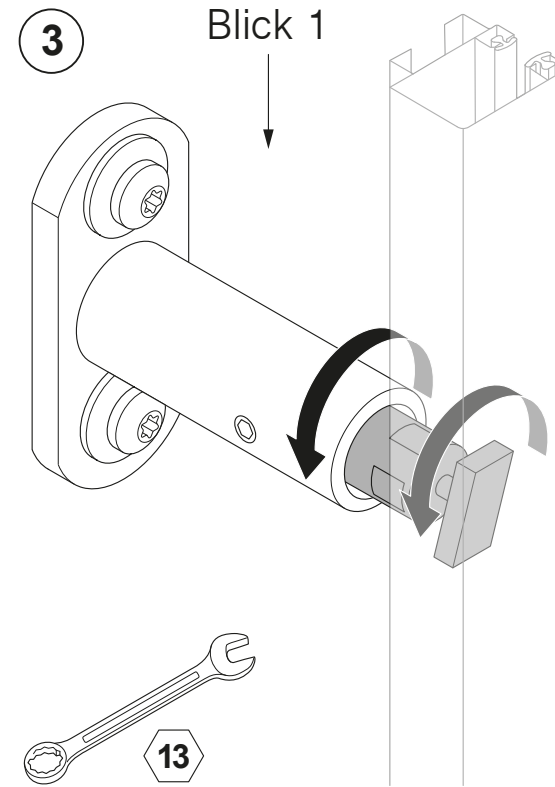
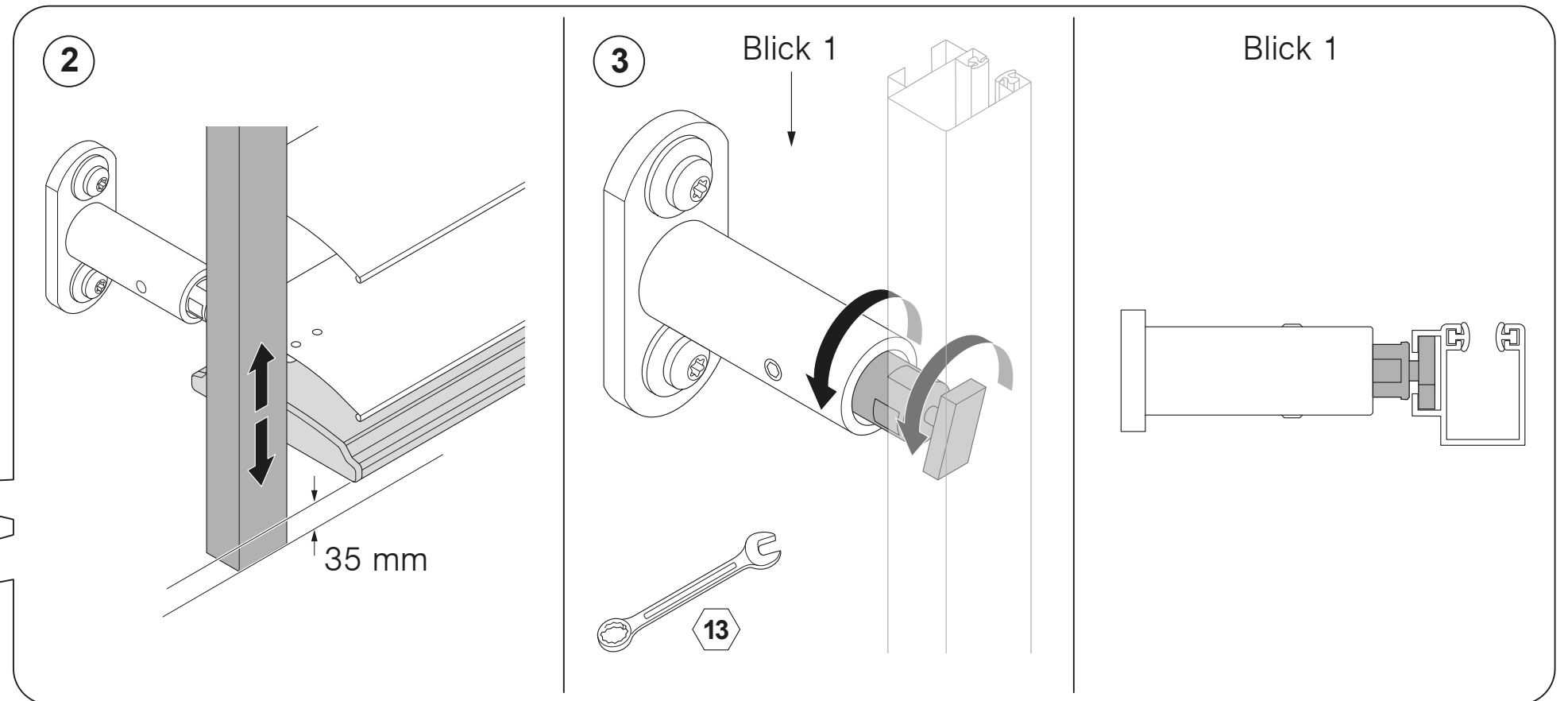
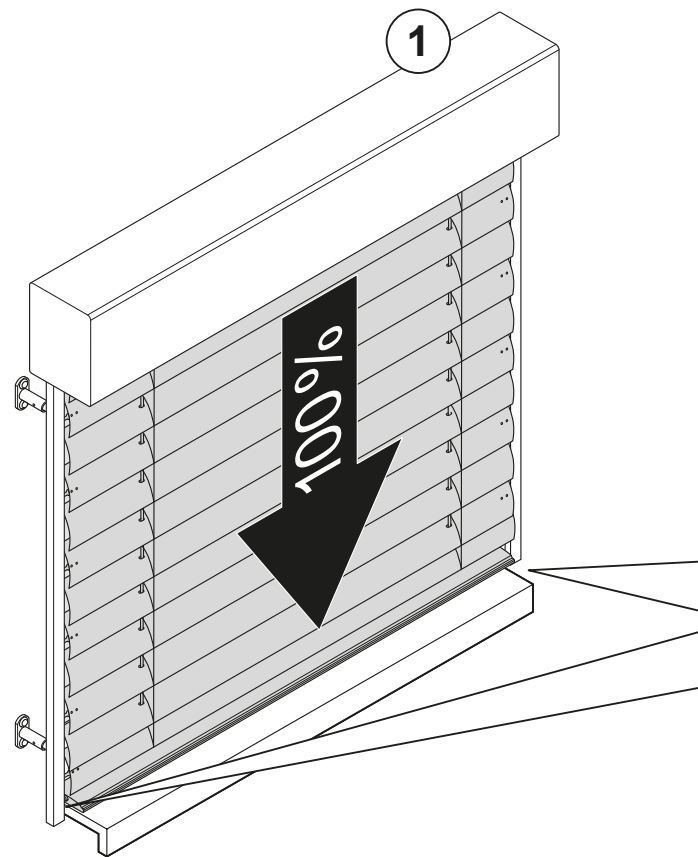

# Führungsschiene vertikal ausrichten (Abstandshalter Typ A/B/C)



X-Maß: siehe Seite 13

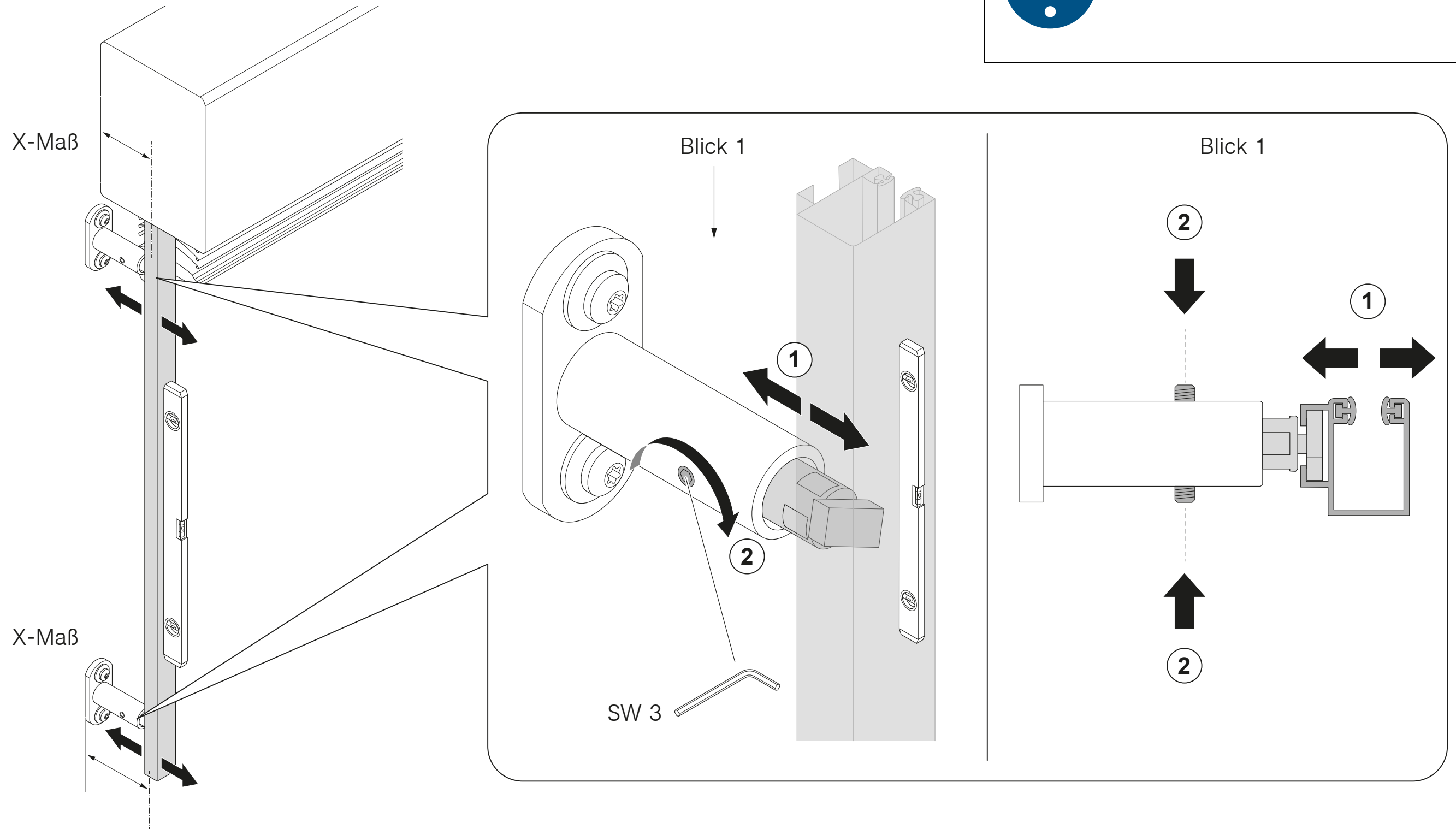



# Profil Typ P auf Montageuntergrund befestigen

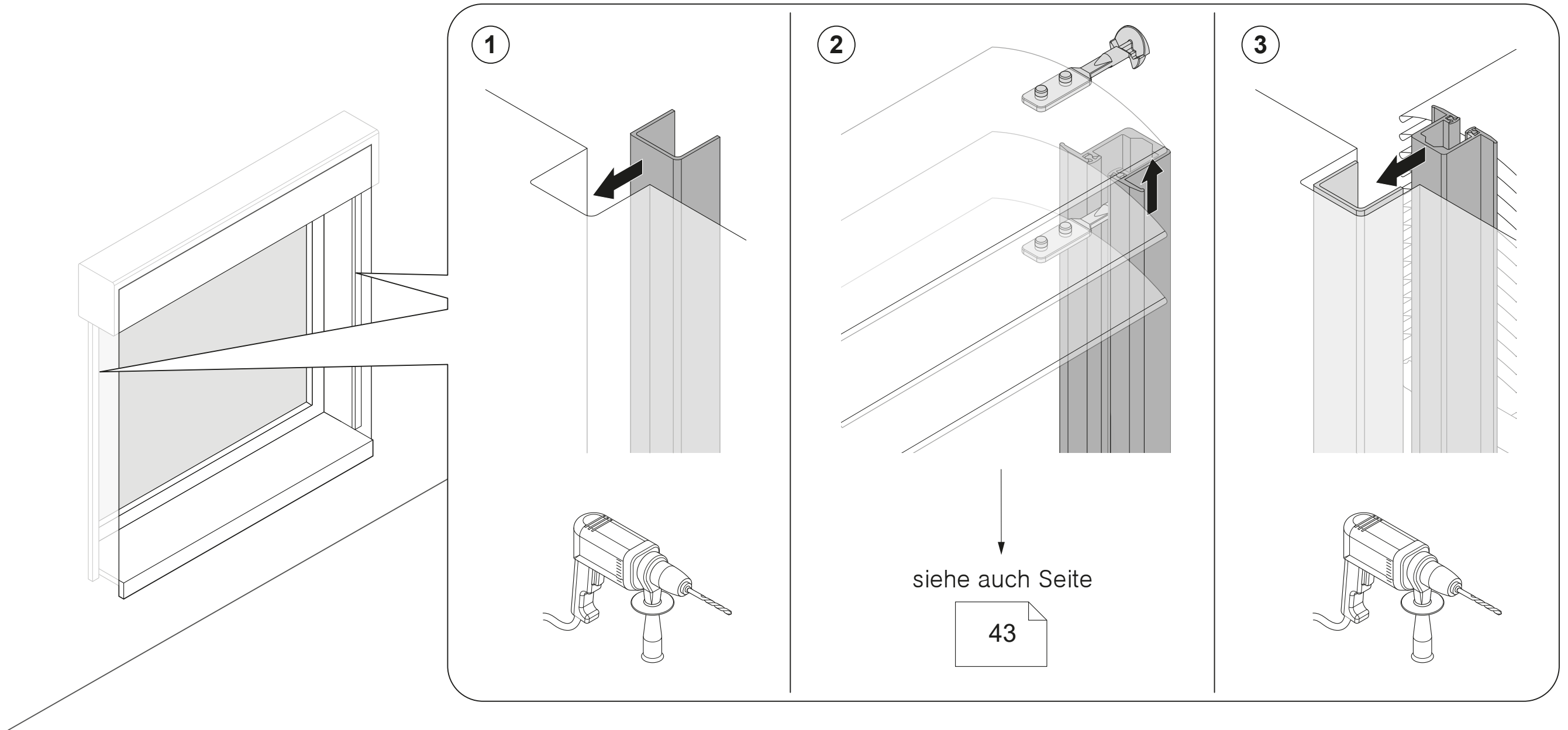

# Profil Typ E30 auf Montageuntergrund befestigen

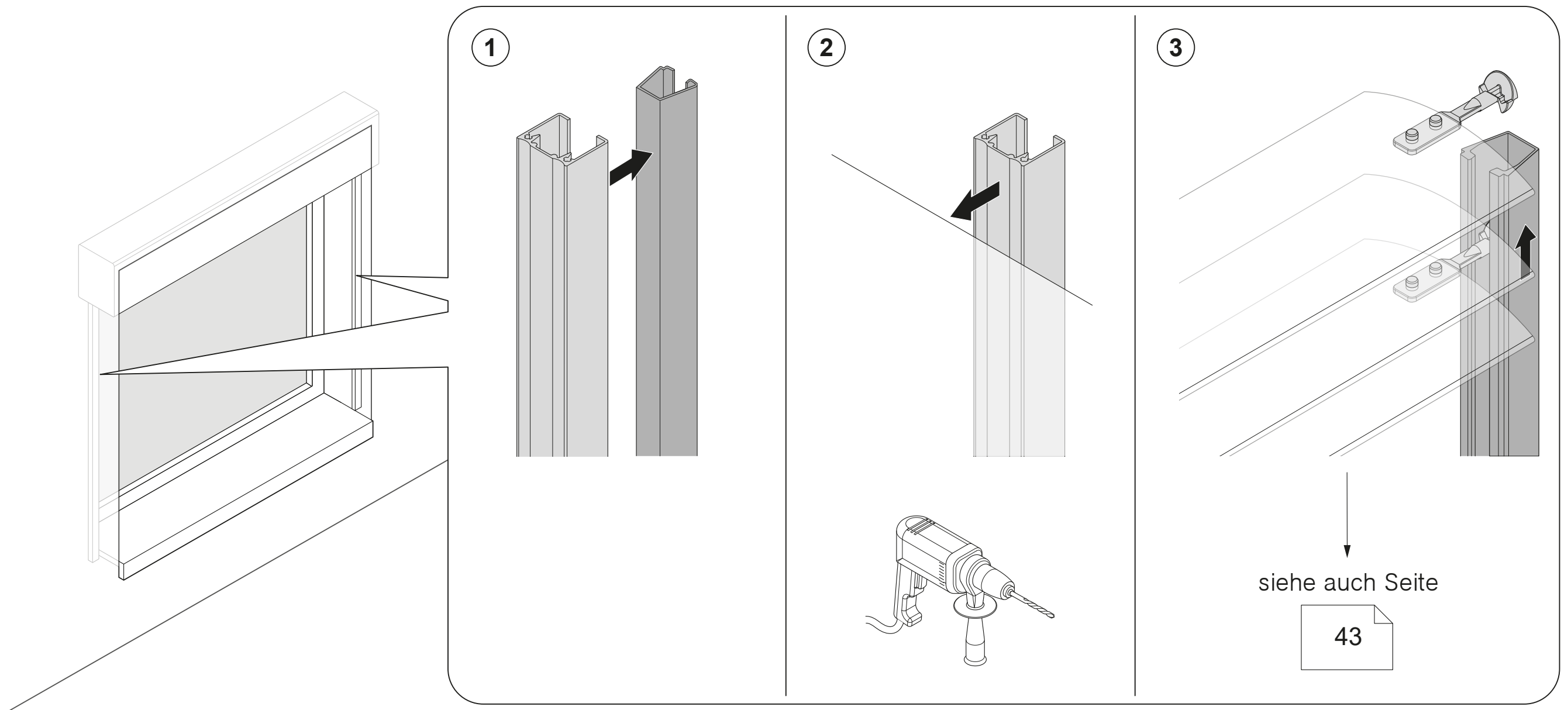

# Profil Typ E30 auf Montageuntergrund befestigen



Für Finger besteht  
Quetschgefahr

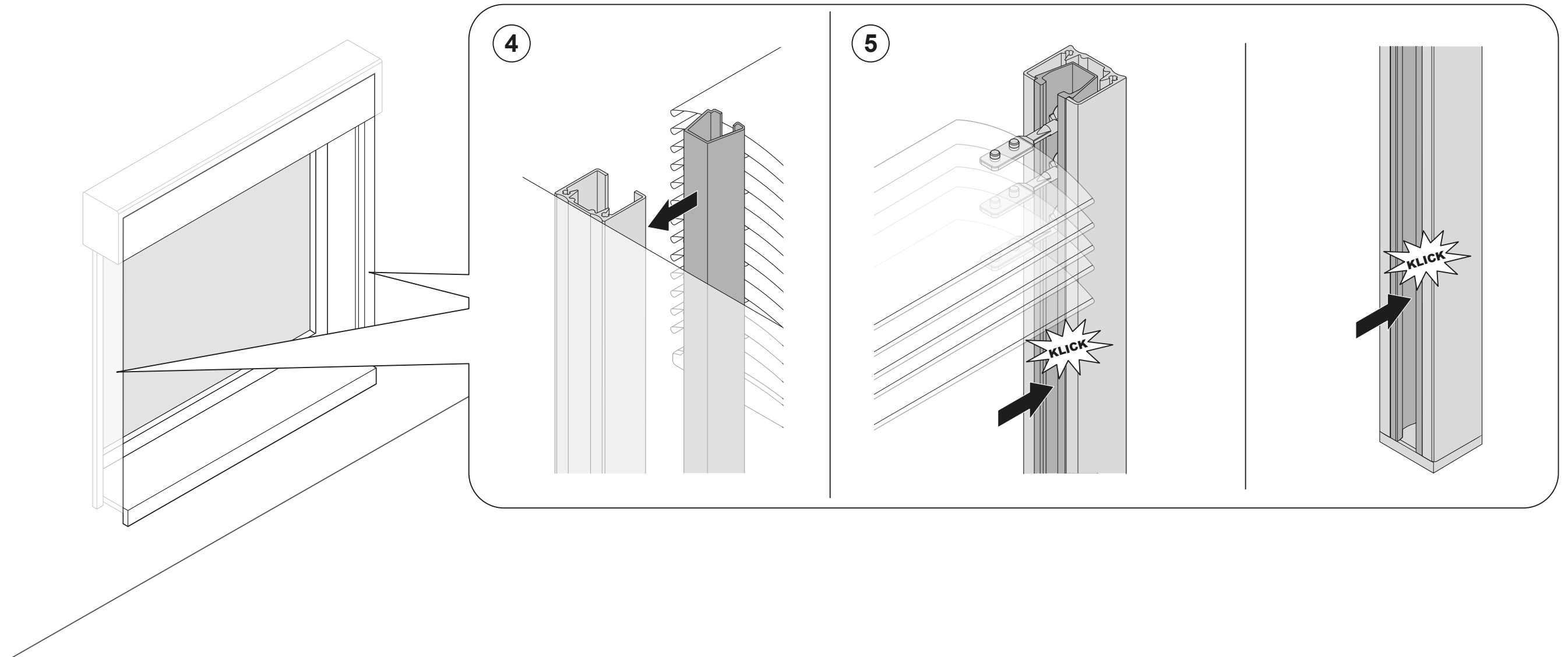

5

## Kabel anschließen

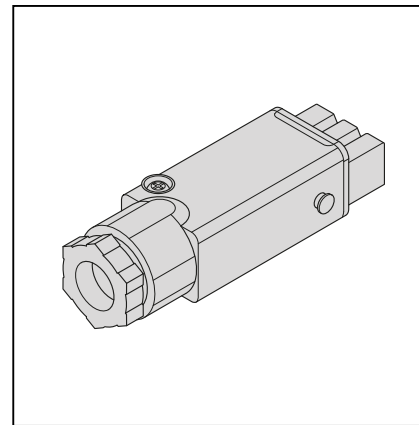

# Hirschmann-Kupplung anschließen



Der Elektroanschluss muss VDE-gerecht von Fachpersonal durchgeführt werden!

Kupplung zur Zuleitung STAK 3

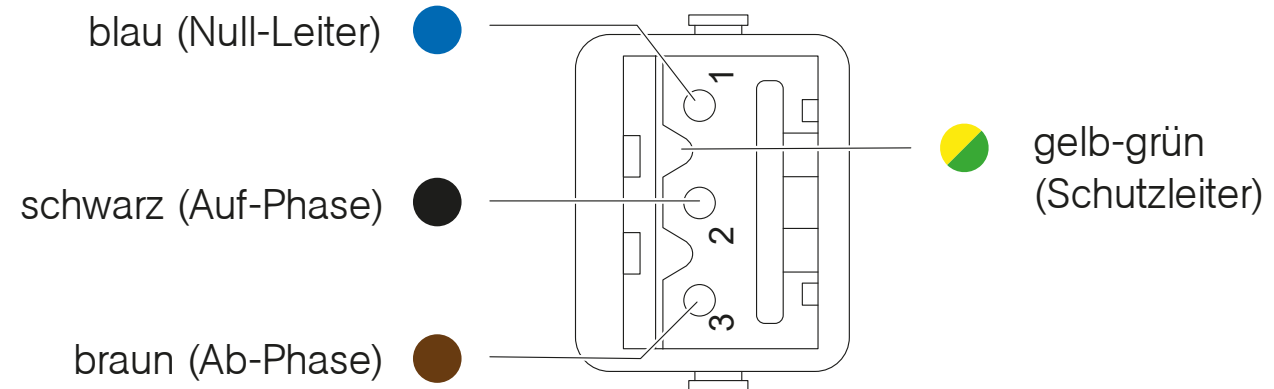
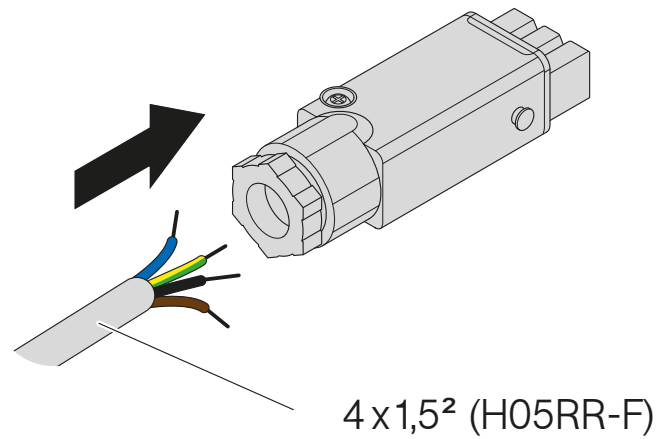

Stecker zum Motor STAS 3

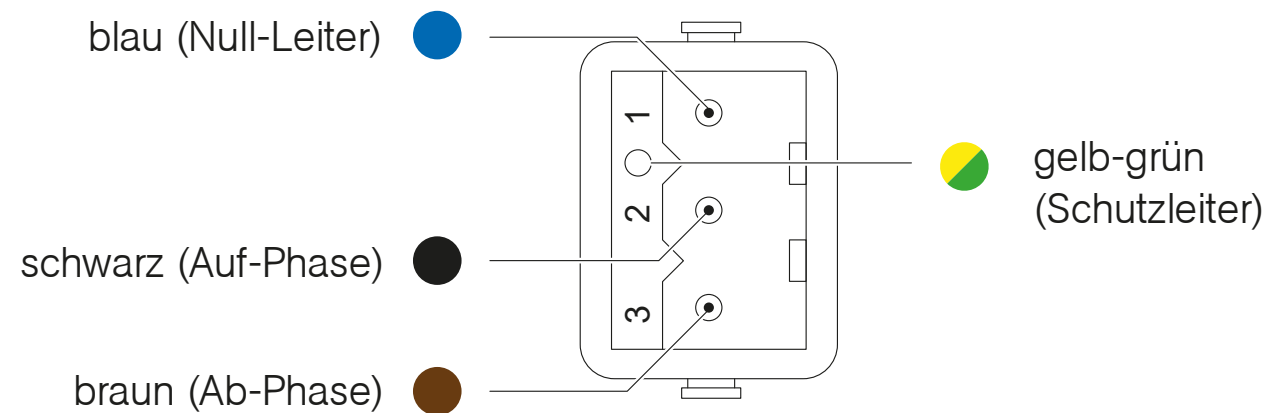
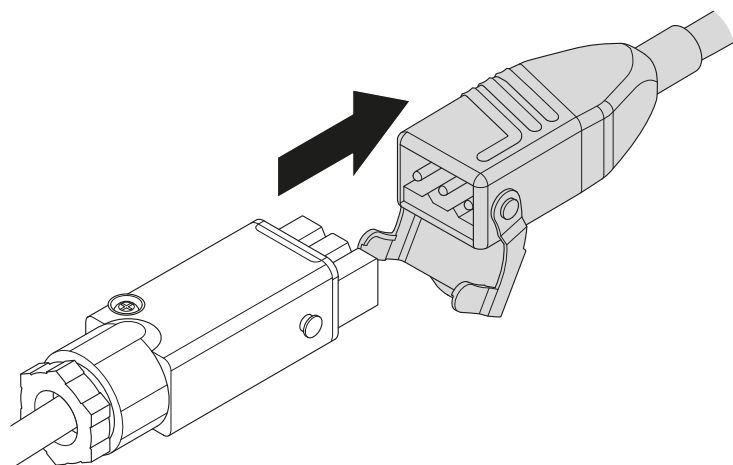

## Kabel in Kabelklemme einhängen



Steckverbindung zwischen  
den beiden Kabelklemmen  
einhängen!

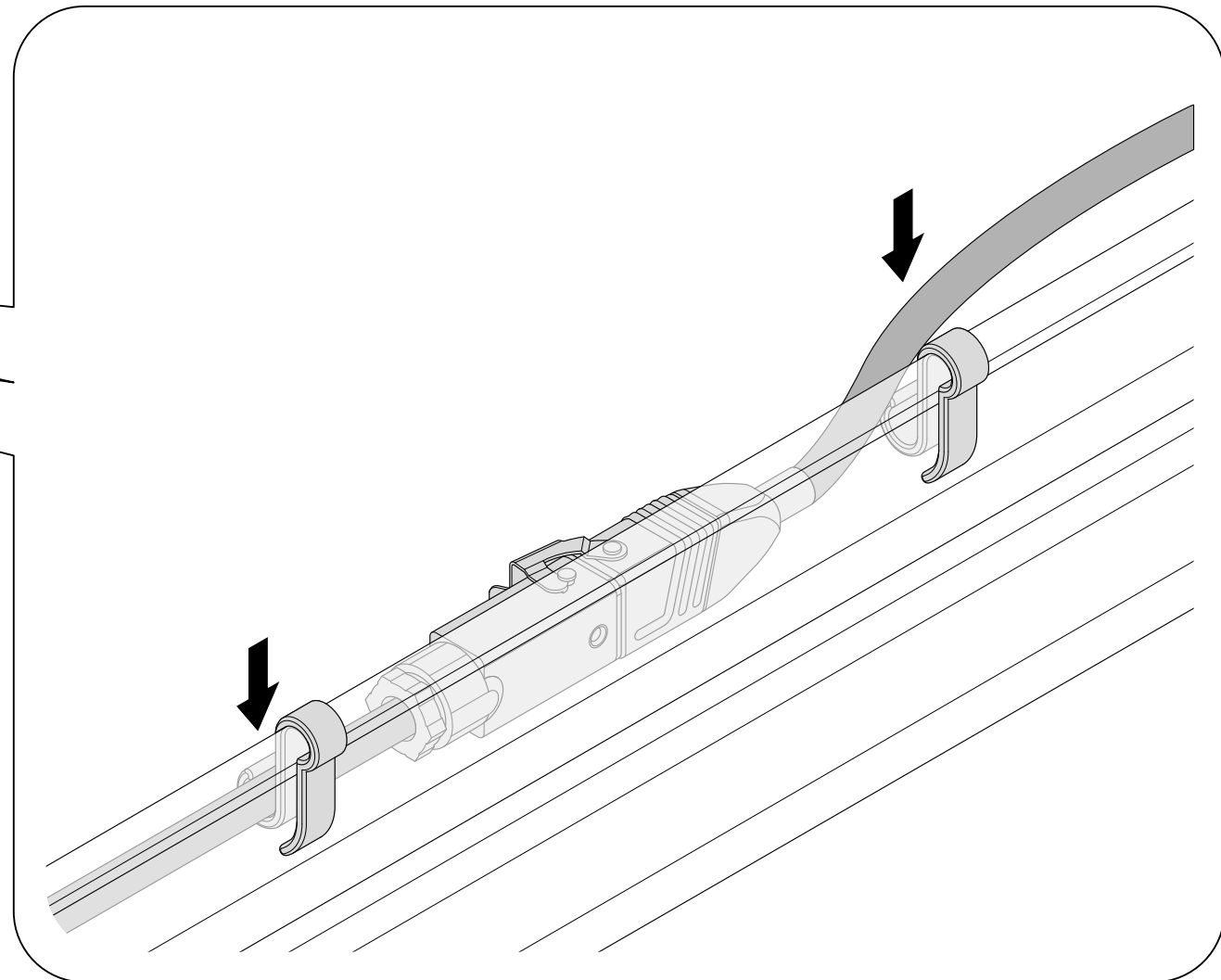
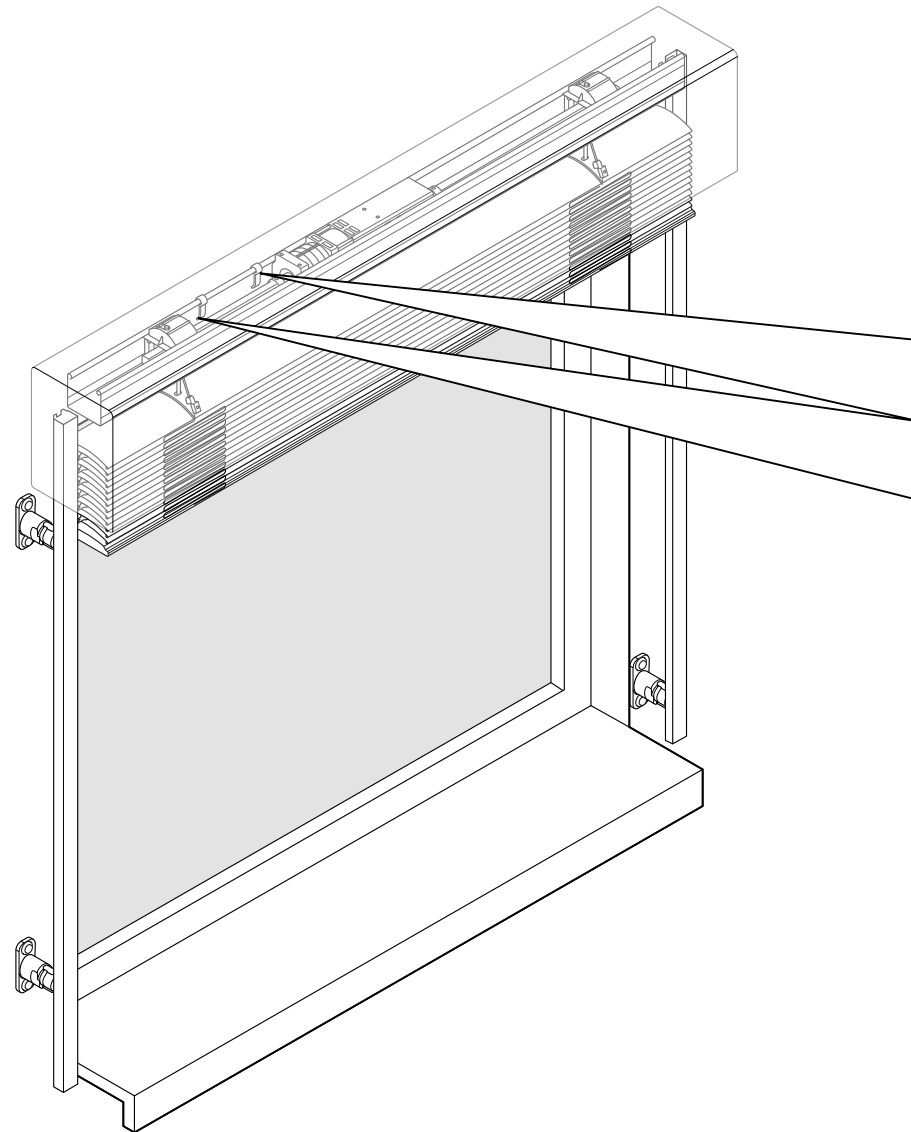

# Test und Übergabe

Test	Beschreibung
1	Befestigungen auf festen Sitz prüfen.
2	Funktionskontrolle (Probelauf)
3	optische Kontrolle der Endlagen

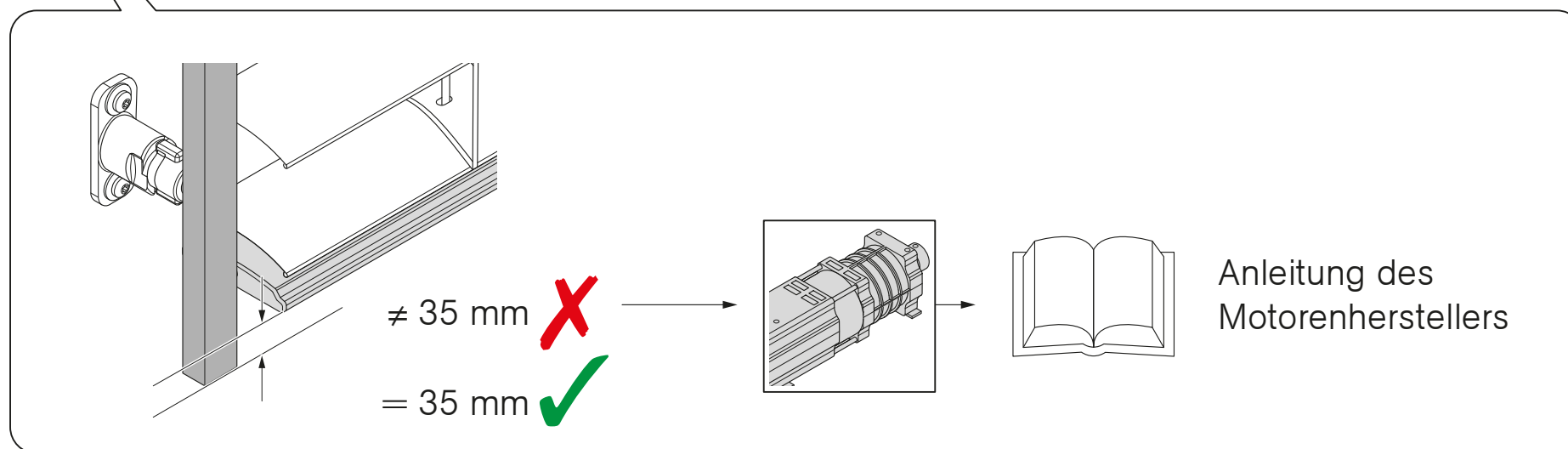
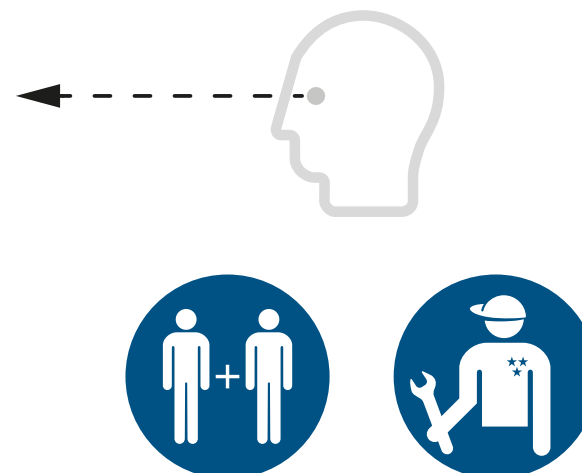
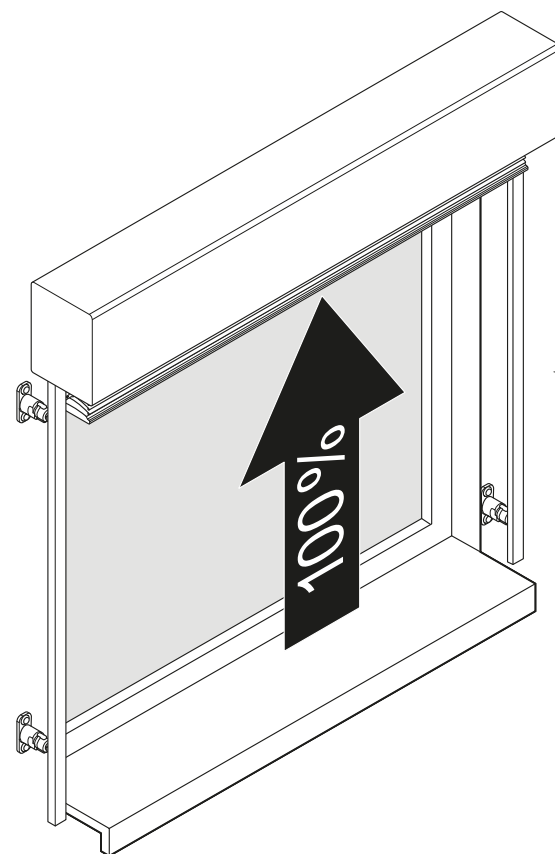
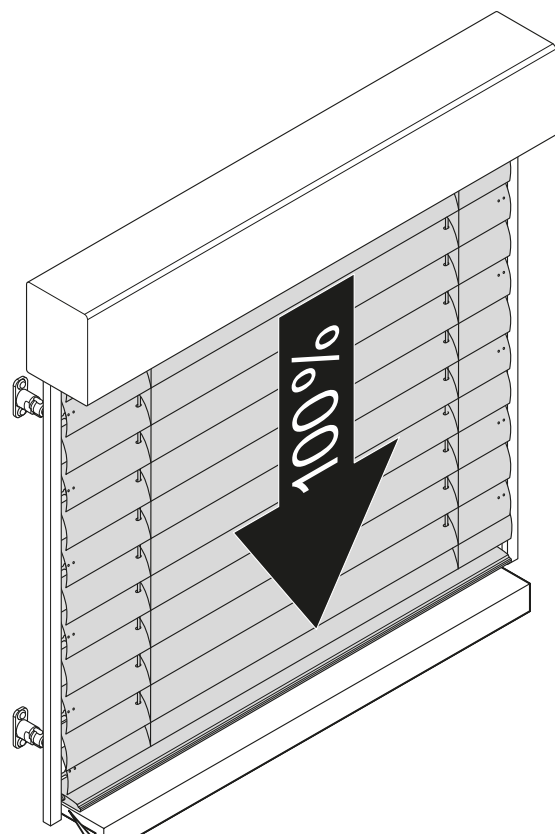

## Onlineshop

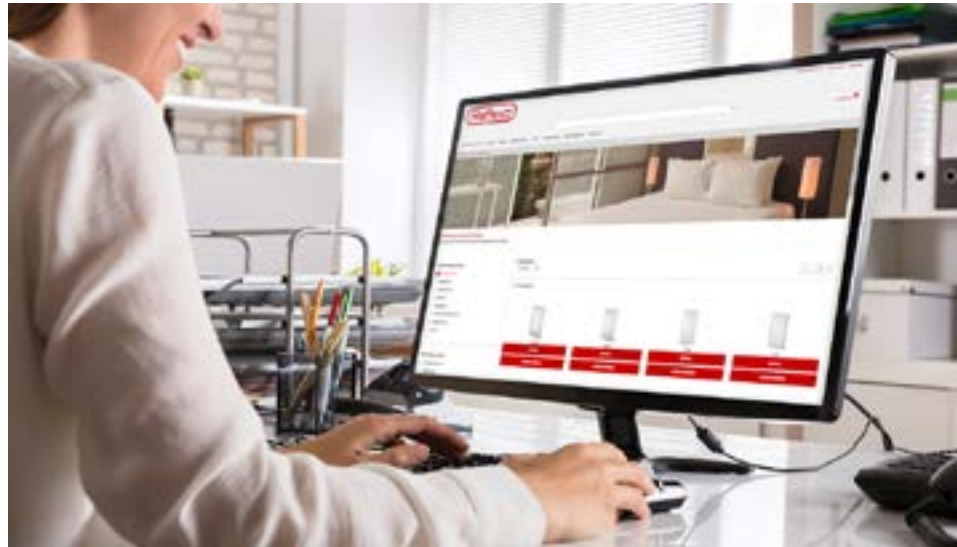

Konfigurieren und bestellen Sie unser umfassendes Produktsortiment, Musterartikel und Werbemittel rund um die Uhr zu Ihren persönlichen Einkaufskonditionen.

## Interaktive Bestellformulare



- » Bestellen Sie per interaktivem PDF-Formular.
- » lückenlose Eingabe dank vordefinierter Eingabefelder
- » ressourcenschonendes Arbeiten durch  
Papiervermeidung
- » schnelleres Bearbeiten Ihrer Bestellung = kürzere  
Lieferzeiten

REFLEXA-WERKE  
Albrecht GmbH

Silbermannstraße 29  
89364 Rettenbach

Tel.: +49 (0) 8224 999-0  
[www.reflexa.de](http://www.reflexa.de)  
[info@reflexa.de](mailto:info@reflexa.de)